

MILD TEMP WALL HYDRANT



8601MT-175

ANTI-SIPHON WALL HYDRANT WITH INTEGRAL BACKFLOW PREVENTER, ALL BRONZE INTERIOR PARTS, 1/2 TURN CERAMIC DISC, COMBINATION 3/4 (19) FEMALE SOLDER & 3/4 (19) MALE NPT PIPE THREAD INLET, KEY OPERATOR AND STAINLESS STEEL BOX W/ HINGED LID.

Approval Date

Customer Approval

Job Location

Job Name

Wade Division / Tyler Pipe Assumes No Responsibility For Superseded or Voided Data

Dimensional Data (Inches/mm) are Subject to Manufacturers Tolerance and Change Without Notice.

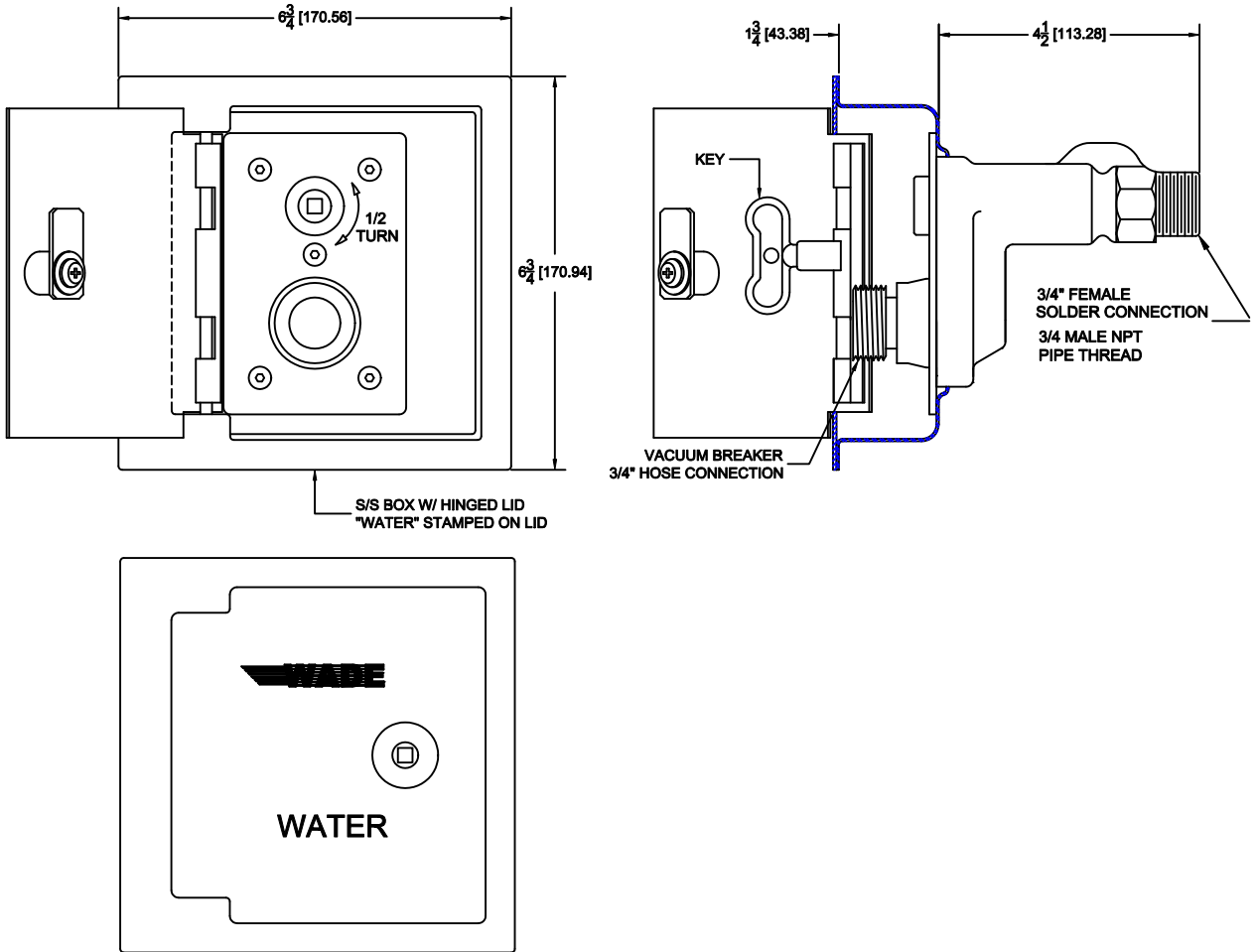

AutoCad.dwg

MILD TEMP WALL HYDRANT



8601MT-175

ANTI-SIPHON WALL HYDRANT WITH INTEGRAL BACKFLOW PREVENTER, ALL BRONZE INTERIOR PARTS, 1/2 TURN CERAMIC DISC, COMBINATION 3/4 (19) FEMALE SOLDER & 3/4 (19) MALE NPT PIPE THREAD INLET, KEY OPERATOR AND STAINLESS STEEL BOX W/ HINGED LID.

Approval Date

Customer Approval

Job Location

Job Name

Wade Division / Tyler Pipe Assumes No Responsibility For Superseded or Voided Data

Dimensional Data (Inches/mm) are Subject to Manufacturers Tolerance and Change Without Notice.

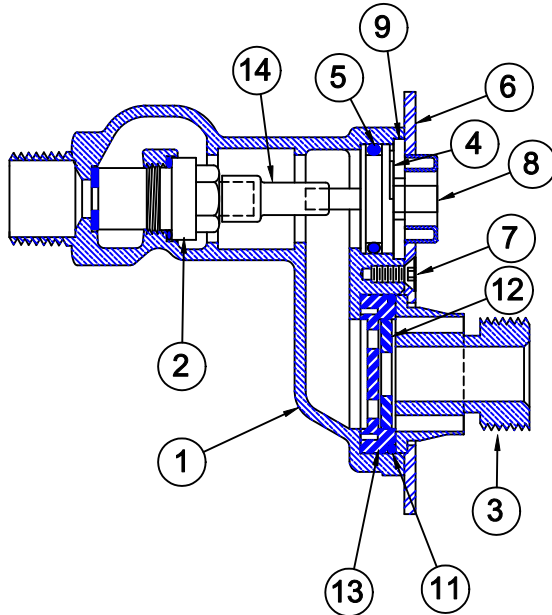
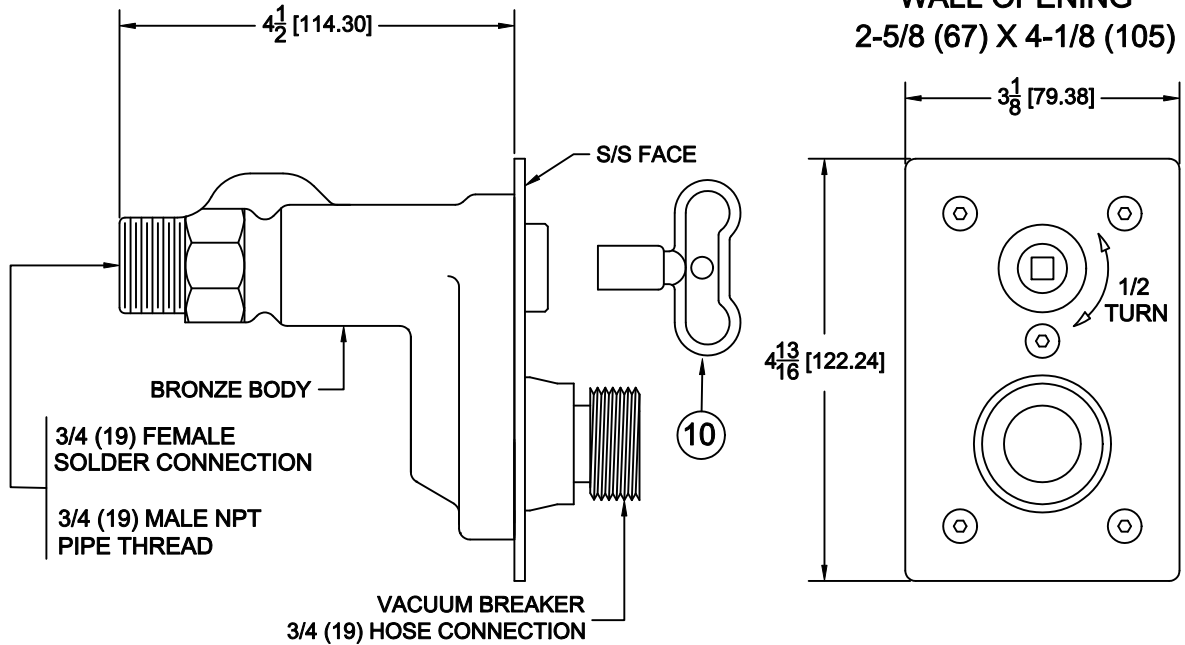

NO.	DESCRIPTION	UPC 670610
1	HYDRANT HEAD	433521
2	CARTRIDGE ASSEMBLY	433545
3	VACUUM BREAKER NOZZLE	433705
4	O-RING (DRAIN OPENING)	433637
5	O-RING (OPERATING COUPLING)	433620
6	FACEPLATE ASSEMBLY	433699
7	FACE PLATE SCREW 10-24NC	263548
8	OPERATING COUPLING	433644
9	THRUST WASHER	433668
10	OPERATING KEY	433651
11	O-RING (DISC SEAL)	433712
12	BALANCE SEAL	433682
13	DISC (VACUUM BREAKER)	433675
14	CONTROL ROD	433903
2,4,5 8,9,10	REPAIR KIT	435334

AutoCad.dwg

MILD TEMP WALL HYDRANT



8601MT-175

ANTI-SIPHON WALL HYDRANT WITH INTEGRAL BACKFLOW PREVENTER, ALL BRONZE INTERIOR PARTS, 1/2 TURN CERAMIC DISC, COMBINATION 3/4 (19) FEMALE SOLDER & 3/4 (19) MALE NPT PIPE THREAD INLET, KEY OPERATOR AND STAINLESS STEEL BOX W/ HINGED LID.

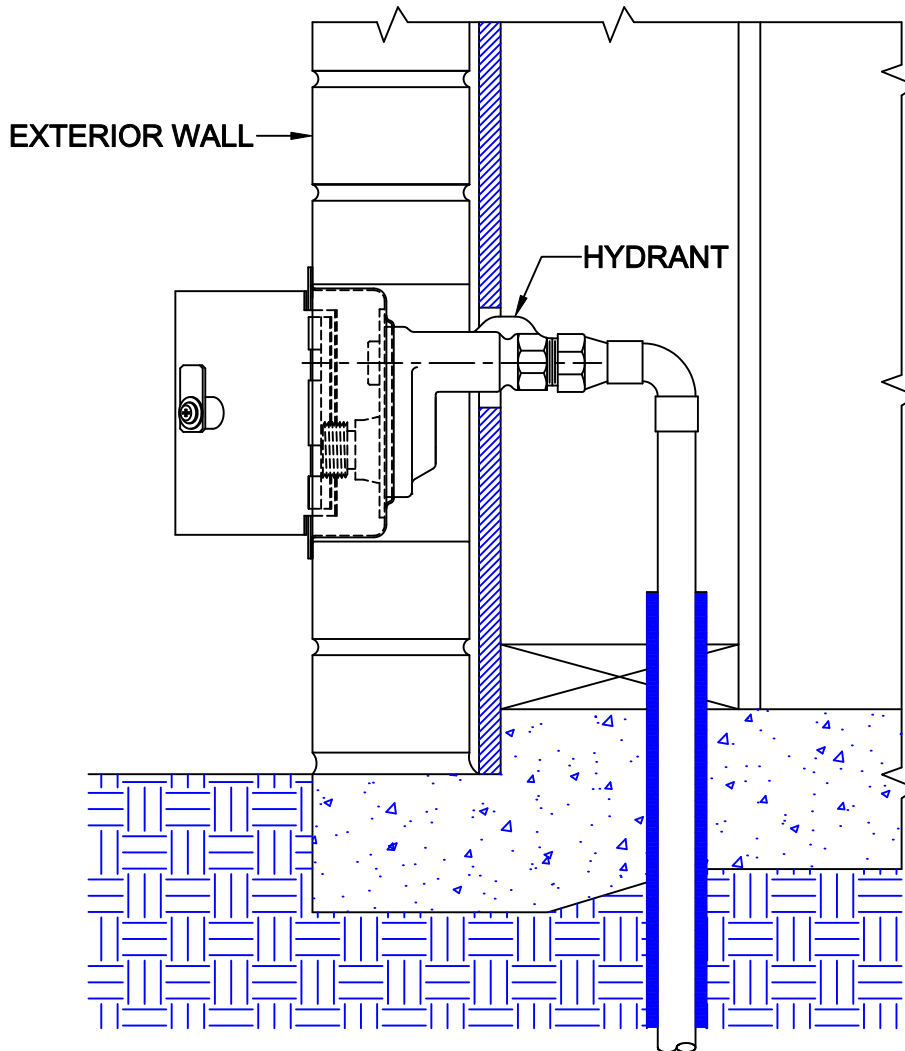

The Wade 8601-175 wall hydrant provides a non-freeze installation in any type of wall construction. The water supply piping is first run to an elevation above the finished floor level at the anticipated hydrant location. The piping should be insulated for protection against aggressive soils and concrete. The type of piping and connections are irrelevant - a standard 3/4" NPT threaded adapter is all that is required. The piping should be accessible for connection after the concrete is poured. A common method is to place the hydrant at an interior wall junction to allow a maximum length for freeze protection.

After the concrete is poured and wall framing is complete, mount the hydrant through the exterior sheeting and into the interior wall. Before connection to the water supply, flush the supply piping to insure no debris exist which could damage or clog the hydrant. The hydrant should extend out to the anticipated finish wall thickness. Use a high quality thread sealant and screw the adapter onto the threaded hydrant tailpiece.

Care must be taken to protect the hydrant during installation. Use either cardboard, tape or other materials to protect the hydrant during construction. After the finish wall is complete, operate the hydrant with the provided key to insure the unit operates properly.

AutoCad.dwg

MILD TEMP WALL HYDRANT



8601MT-175

ANTI-SIPHON WALL HYDRANT WITH INTEGRAL BACKFLOW PREVENTER, ALL BRONZE INTERIOR PARTS, 1/2 TURN CERAMIC DISC, COMBINATION 3/4 (19) FEMALE SOLDER & 3/4 (19) MALE NPT PIPE THREAD INLET, KEY OPERATOR AND STAINLESS STEEL BOX W/ HINGED LID.

Troubleshooting Guide

PROBLEM	CAUSE	SOLUTION
Hydrant will not operate when turned on	Water supply is off	Turn water supply on
Cannot turn the hydrant on with the key	Hydrant has not been operated for a long period - O-ring has adhered to stem and head	See service guide steps 1-2, 4-5 and 8-10
	Ceramic disc inside cartridge assembly is broken	See service guide steps 1-2, 4 and 6-10
Water sprays from holes around vacuum breaker nozzle when hydrant is on	Balance seal is damaged	See service guide steps 1-3 and 8-10
Water sprays from around the key operator when the hydrant is on	Operating coupling o-ring or the air relief orifice o-ring is damaged	See service guide steps 1-2, 4-5 and 8-10
Hydrant weeps around the operating key area	This is normal (hydrant will self drain for a short period after it is off)	Take no action
Hydrant will not weep (self drain) after it is shut off and a hose is attached	The air relief orifice is blocked	Use a paper clip to evacuate debris from the orifice
Hydrant will not shut off completely	Cartridge assembly is loose or damaged	See service guide steps 1-2, 4 and 6-10 (Verify that cartridge assembly is tight/seated)
	Debris in the ceramic disc or disc is damaged	See service guide steps 1-2, 4 and 6-10
Hydrant has low flow	Water supply to the hydrant is restricted	Check water supply to ensure that all upstream valves are fully open
	Debris has accumulated at the ceramic disc cartridge	See service guide steps 1-2, 4 and 6-10

Service Guide

Step 1: Shut Off Water Supply to Hydrant.

Locate the supply shut-off valve and actuate until water supply is off.

Step 2: Removing Faceplate and Internal Components

Use a screwdriver or cordless drill with appropriate bit to remove the faceplate screws (5) by turning counterclockwise. Remove the faceplate, vacuum breaker nozzle and retaining washer. If the balance seal was not the reason for service, skip to step 4.

Step 4: Replacing the Balance Seal

Remove the balance seal and check for damage. Replace if necessary. The proper orientation is with the seal cup inward in its replaced state.

Step 5: Replacing Operating Coupling O-Ring and the Air Relief Orifice O-Ring

Slip the operating coupling o-ring off and replace with a new o-ring. Remove the air relief o-ring and replace.

If the cartridge assembly is not the reason for service, skip to step 8.

Step 6: Removing The Cartridge and Operating Rod Assemblies

Grasp the operating rod with needle nose pliers and pull the rod out. Insert the 17mm cartridge wrench into the casing and engage the hex portion of the cartridge assembly. Turn the wrench counterclockwise until the cartridge is completely unscrewed and free. Remove the assembly.

IMPORTANT: Ensure that the entire cartridge is removed and the area is free of debris.

If low flow was the reason for service, turn the water supply on for a short time to flush any residual debris.

Turn the water supply off again.

Step 7: Installing the Cartridge and Operating Rod Assemblies

Place the new cartridge assembly into the 17mm cartridge wrench and engaged onto the hex portion of the assembly. Insert the cartridge assembly with the wrench into the hydrant casing and align with the internal threads. Rotate the wrench clockwise screwing the cartridge into the valve body until the assembly is snug. About 15 Lb/Ft of torque is sufficient. Insert the operating coupling into the case and engage the splined shaft. Make sure the cartridge assembly is in the off position.

Step 8: Installing the Operating Coupling and Retainer Washer

Orient the operating coupling so that the air relief orifice is in the upper position. Press the operating coupling into the hydrant head and engages the operating rod. Note: Lubricate the O-ring with Lubriplate FLG-2 or a suitable food grade lubricant. Insert the retaining washer onto the operating coupling ensuring that the guide pin fits into the operating coupling groove properly and that the air relief orifice is aligned. Lubricate the orifice o-ring lightly along with the operating coupling.

Step 9: Replacing the Faceplate

Insert the vacuum breaker nozzle and secure the faceplate with the (5) screws snugged tight. Hand tighten only.

Step 10: Turn On the Water Supply

Locate the water supply valve and actuate open. Open and close the hydrant to ensure it works correctly.

Approval Date / Customer Approval / Job Location / Job Name / Dimensional Data (Inches/mm) are Subject to Manufacturers Tolerance and Change Without Notice. Wade Division / Tyler Pipe Assumes No Responsibility For Superseded or Voided Data

MILD TEMP WALL HYDRANT



8601MT-175

ANTI-SIPHON WALL HYDRANT WITH INTEGRAL BACKFLOW PREVENTER, ALL BRONZE INTERIOR PARTS, 1/2 TURN CERAMIC DISC, COMBINATION 3/4 (19) FEMALE SOLDER & 3/4 (19) MALE NPT PIPE THREAD INLET, KEY OPERATOR AND STAINLESS STEEL BOX W/ HINGED LID.

HYDRANT PERFORMANCE

Static Pressure (PSI)	Running Inlet Pressure (PSI)	Running Outlet Pressure (PSI)	Flow Rate (GPM)
10	6.1	0.0	2.6
20	14.8	0.0	4.3
30	24.3	0.5	5.6
40	33.1	0.9	6.5
50	42.3	1.4	7.3
60	49.7	1.7	7.9
70	62.1	2.2	8.8
80	70.6	2.7	9.3
90	78.7	3.1	9.8

Approval Date

Customer Approval

Job Location

Job Name

Dimensional Data (Inches/mm) are Subject to Manufacturers Tolerance and Change Without Notice.

Wade Division / Tyler Pipe Assumes No Responsibility For Superseded or Voided Data