

NON-FREEZE WALL HYDRANT



8600

ANTI-SIPHON WALL HYDRANT WITH INTEGRAL BACKFLOW PREVENTER, ALL BRONZE INTERIOR PARTS, 3/4" FEMALE IPS THREADED INLET, BRONZE CASING, KEY OPERATOR, TEE HANDLE KEY AND BRONZE FACE.

Approval Date

Customer Approval

Job Location

Job Name

Wade Division / Tyler Pipe Assumes No Responsibility For Superseded or Voided Data
 Wade Division / Tyler Pipe Assumes No Responsibility For Superseded or Voided Data
 Dimensional Data (Inches/mm) are Subject to Manufacturers Tolerance and Change Without Notice.

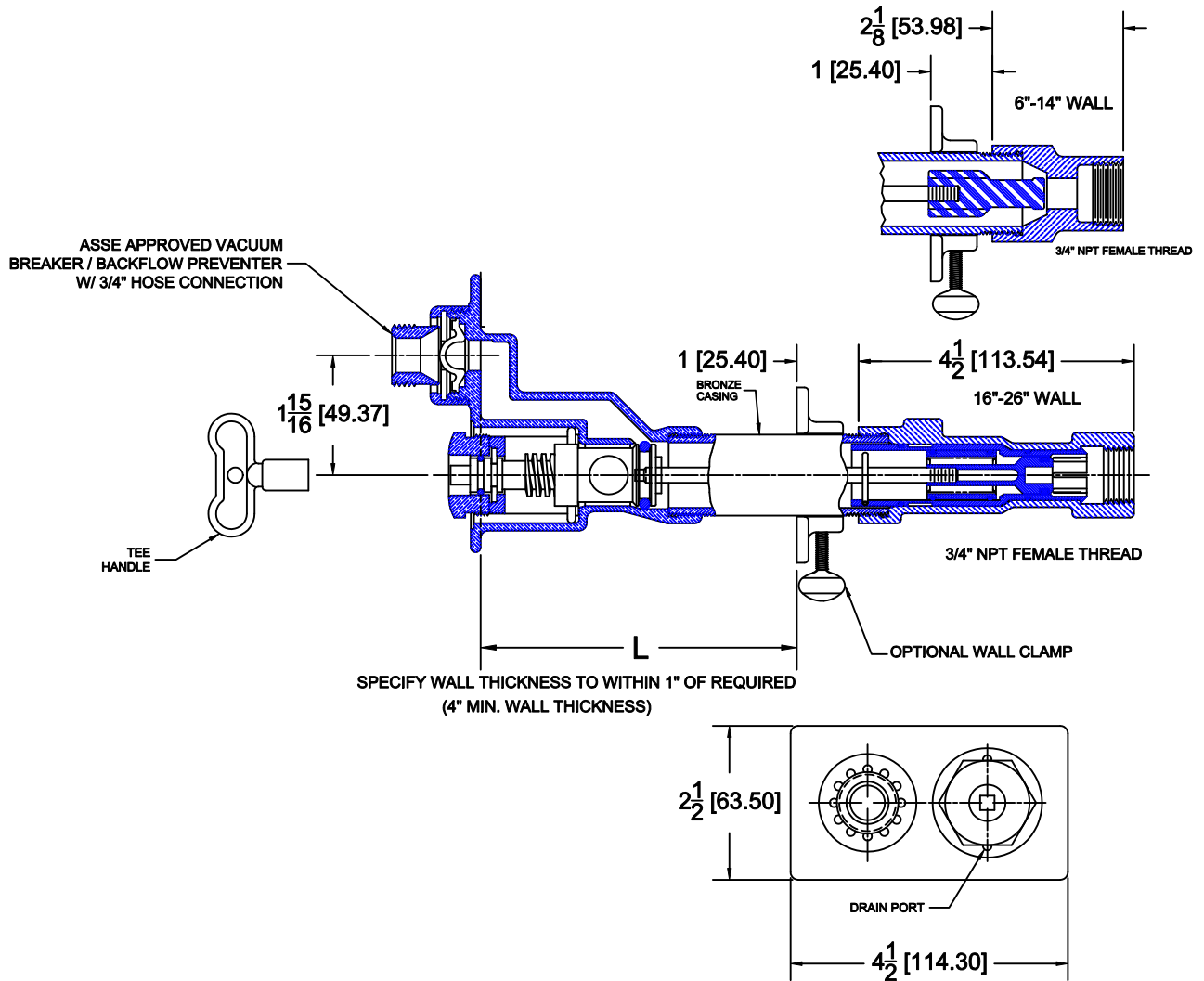

Catalog No.	Hose Size	'L' (Length)
<input type="checkbox"/> 8600-L4	3/4 (19)	4 (102)
<input type="checkbox"/> 8600-L6	3/4 (19)	6 (152)
<input type="checkbox"/> 8600-L8	3/4 (19)	8 (203)
<input type="checkbox"/> 8600-L10	3/4 (19)	10 (254)
<input type="checkbox"/> 8600-L12	3/4 (19)	12 (305)
<input type="checkbox"/> 8600-L14	3/4 (19)	14 (356)

Catalog No.	Hose Size	'L' (Length)
<input type="checkbox"/> 8600-L16	3/4 (19)	16 (406)
<input type="checkbox"/> 8600-L18	3/4 (19)	18 (457)
<input type="checkbox"/> 8600-L20	3/4 (19)	20 (508)
<input type="checkbox"/> 8600-L22	3/4 (19)	22 (559)
<input type="checkbox"/> 8600-L24	3/4 (19)	24 (610)

OPTIONS

Suffix	Description
<input type="checkbox"/> WC	WALL CLAMP

AutoCad.dwg

NON-FREEZE WALL HYDRANT



8600

ANTI-SIPHON WALL HYDRANT WITH INTEGRAL BACKFLOW PREVENTER, ALL BRONZE INTERIOR PARTS, 3/4" FEMALE IPS THREADED INLET, BRONZE CASING, KEY OPERATOR, TEE HANDLE KEY AND BRONZE FACE. INSTALLATION INSTRUCTIONS

Approval Date

Customer Approval

Job Location

Job Name

Wade Division / Tyler Pipe Assumes No Responsibility For Superseded or Voided Data

Dimensional Data (Inches/mm) are Subject to Manufacturers Tolerance and Change Without Notice.

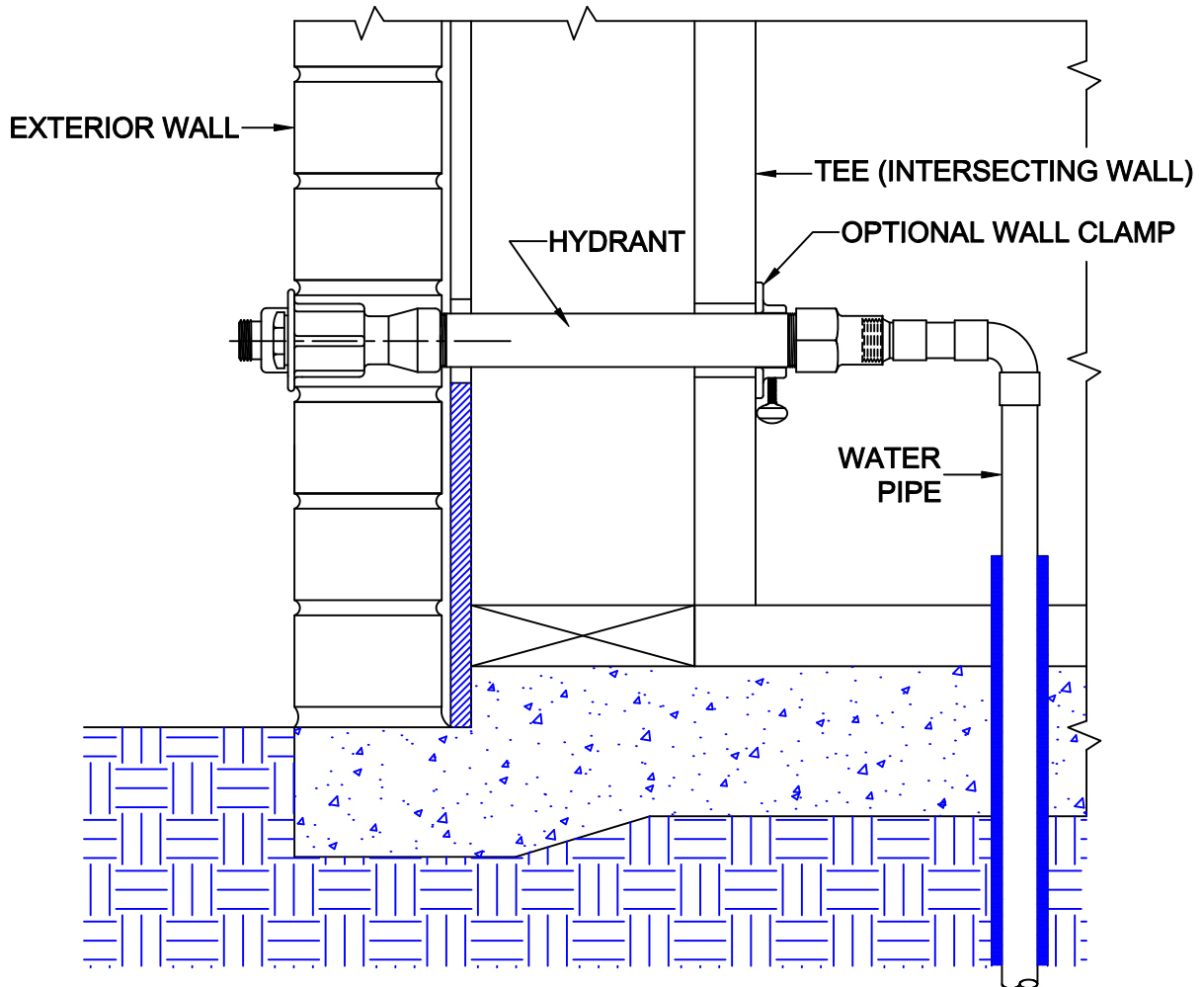

The Wade 8600 wall hydrant provides a non-freeze installation in any type of wall construction. The water supply piping is first run to an elevation above the finished floor level at the anticipated hydrant location. The piping should be insulated for protection against aggressive soils and concrete. The type of piping and connections are irrelevant - a standard 3/4" male NPT threaded adapter is all that is required. The piping should be accessible for connection after the concrete is poured. A common method is to place the hydrant at an interior wall junction to allow a maximum length for freeze protection.

After the concrete is poured and wall framing is complete, mount the hydrant through the exterior sheeting and into the interior wall. Before connection to the water supply, flush the supply piping to insure no debris exist which could damage or clog the hydrant. The hydrant should extend out to the anticipated finish wall thickness. Use a high quality thread sealant and screw the adapter into the threaded hydrant tailpiece.

Care must be taken to protect the hydrant during installation. Use either cardboard, tape or other materials to protect the top during construction. After the finish wall is complete, open the box cover with the provided key and turn the hydrant on to insure the unit operates properly.

AutoCad.dwg

NON-FREEZE WALL HYDRANT



Approval Date

Customer Approval

Job Location

Job Name

Wade Division / Tyler Pipe Assumes No Responsibility For Superseded or Voided Data

8600

ANTI-SIPHON WALL HYDRANT WITH INTEGRAL BACKFLOW PREVENTER, ALL BRONZE INTERIOR PARTS, 3/4" FEMALE IPS THREADED INLET, BRONZE CASING, KEY OPERATOR, TEE HANDLE KEY AND BRONZE FACE. INSTALLATION INSTRUCTIONS

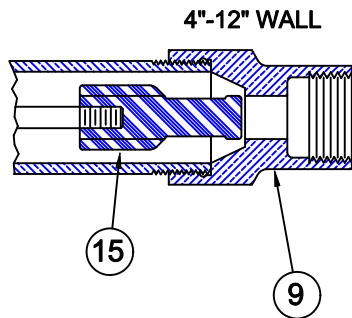
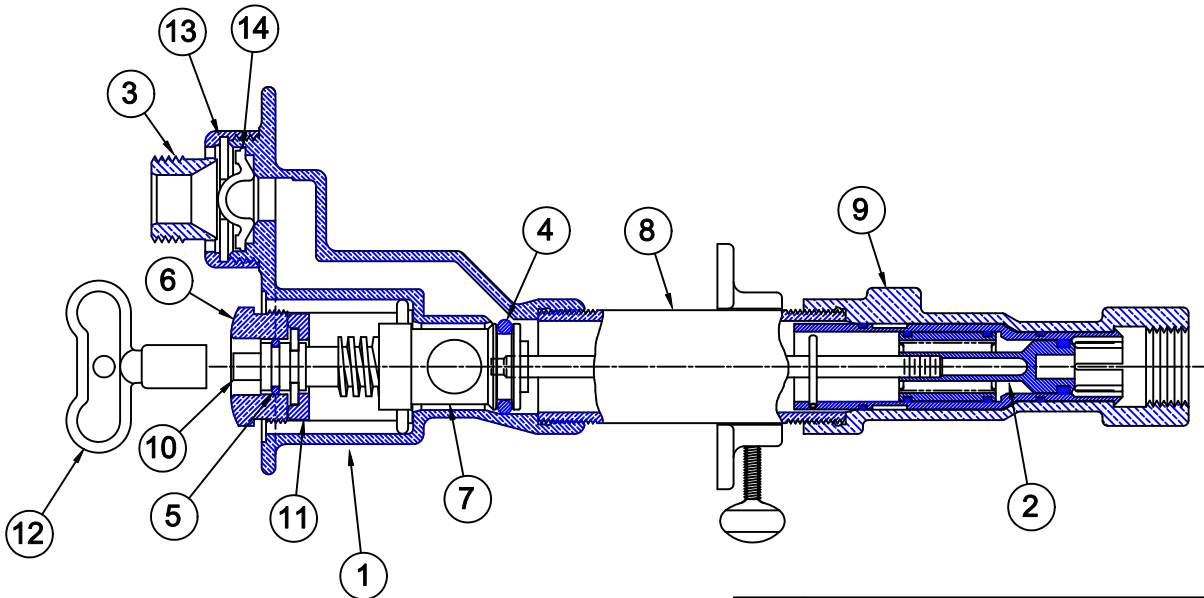

NO.	DESCRIPTION	UPC 670610
2,4,5 10,11,12	MINOR REPAIR KIT WK03 (16-26")	232766
4,5,10 11,12,15	MINOR REPAIR KIT WK01 (6-14")	357629
2,3,4,5,6 7,10-12 13,14	MAJOR REPAIR KIT WK04 (16-26")	232773
3,4,5,6 7,10-12 13,14,15	MAJOR REPAIR KIT WK02 (6-14")	357636

NO.	DESCRIPTION
1	HYDRANT HEAD
2	CARTRIDGE ASSEMBLY
3	VACUUM BREAKER NOZZLE
4	O-RING (DRAIN OPENING)
5	O-RING (OPERATING COUPLING)
6	STEM BUSHING NUT
7	DRIVE SLEEVE
8	CASING
9	VALVE BODY (14-24" WALL)
9	VALVE BODY (6-14" WALL)
10	DRIVE SCREW
11	THRUST WASHER / SEAL
12	OPERATING KEY
13	DIVERTER DIAPHRAM
14	DIVERTER CHECK SPIDER
15	PLUNGER
16	CONTROL ROD (L6)
	CONTROL ROD (L8)
	CONTROL ROD (L10)
	CONTROL ROD (L12)
	CONTROL ROD (L14)
	CONTROL ROD (L16)
	CONTROL ROD (L18)
	CONTROL ROD (L20)
	CONTROL ROD (L22)
	CONTROL ROD (L24)
	CONTROL ROD (L26)

NON-FREEZE WALL HYDRANT



8600

ANTI-SIPHON WALL HYDRANT WITH INTEGRAL BACKFLOW PREVENTER, ALL BRONZE INTERIOR PARTS, 3/4" FEMALE IPS THREADED INLET, BRONZE CASING, KEY OPERATOR, TEE HANDLE KEY AND BRONZE FACE.
INSTALLATION INSTRUCTIONS

Troubleshooting Guide

PROBLEM	CAUSE	SOLUTION
Hydrant will not operate when turned on	Water supply is off	Turn water supply on
Cannot turn the hydrant on with the key	Hydrant has not been operated for a long period - O-ring has adhered to stem and head	See service guide steps 1-2, 4-5 and 8-10
	Ceramic disc inside cartridge assembly is broken	See service guide steps 1-4.
Water sprays from holes around vacuum breaker nozzle when hydrant is on	Balance seal is damaged	See service guide steps 1-3 and 8-10
Water sprays from around the key operator when the hydrant is on	Operating coupling o-ring or the air relief orifice o-ring is damaged	See service guide steps 1-4
Hydrant weeps around the operating key area	This is normal (hydrant will self drain for a short period after it is off)	Take no action
Hydrant will not weep (self drain) after it is shut off and a hose is attached	The air relief orifice is blocked	Use a paper clip to evacuate debris from the orifice
Hydrant will not shut off completely	Cartridge assembly is loose or damaged	See service guide steps 1-4 (Verify that cartridge assembly is tight/seated)
	Debris in the ceramic disc or disc is damaged	See service guide steps 1-2, 4 and 6-10
Hydrant has low flow	Water supply to the hydrant is restricted	Check water supply to ensure that all upstream valves are fully open

Service Guide

Step 1: Shut Off Water Supply to Hydrant.

Locate the supply shut-off valve and actuate until water supply is off.

Step 2: Removing Internal Components

Use a wrench of appropriate size to remove the stem bushing nut by turning counterclockwise.

With a key operator, turn the drive screw 3 to 4 turns clockwise to let the drive screw assembly protrude slightly from the hydrant face. Using (2) screwdrivers or vise-grip pliers, pull to release the internal operating assembly.

Step 3: Replacing Operating Stem and Internal Seals

Unscrew the plunger/cartridge assembly from the operating rod. Screw a new plunger or cartridge assembly onto the rod.

Remove the o-ring seal from the on the drive sleeve and replace with the new o-ring in the kit.

Reassemble the drive screw, drive sleeve, operating rod, cartridge assembly / plunger.

Insert assembly into the hydrant with the square drive sleeve aligned with its square bore. Grasp the head of the drive screw with pliers and gently push and pull the assembly to insure the cartridge assembly is properly engaged. For hydrants with a neoprene plunger, this step is not required.

Unscrew the drive screw from the sleeve and install the nylon thrust washer / seal and stem bushing nut.

Operate the hydrant fully open and closed to check for normal operation.

Step 4: Turn On the Water Supply

Locate the water supply valve and actuate open. Open and close the hydrant to ensure it works correctly.

HYDRANT PERFORMANCE

Static Pressure (PSI)	Running Inlet Pressure (PSI)	Running Outlet Pressure (PSI)	Flow Rate (GPM)
10	6.1	0.0	2.6
20	14.8	0.0	4.3
30	24.3	0.5	5.6
40	33.1	0.9	6.5
50	42.3	1.4	7.3
60	49.7	1.7	7.9
70	62.1	2.2	8.8
80	70.6	2.7	9.3
90	78.7	3.1	9.8

Approval Date

Customer Approval

Job Location

Job Name

Wade Division / Tyler Pipe Assumes No Responsibility For Superseded or Voided Data.
Dimensional Data (Inches/mm) are Subject to Manufacturers Tolerance and Change Without Notice.