

300-FPO

FEATURES OF ADJUSTABLE CLOSET COUPLING

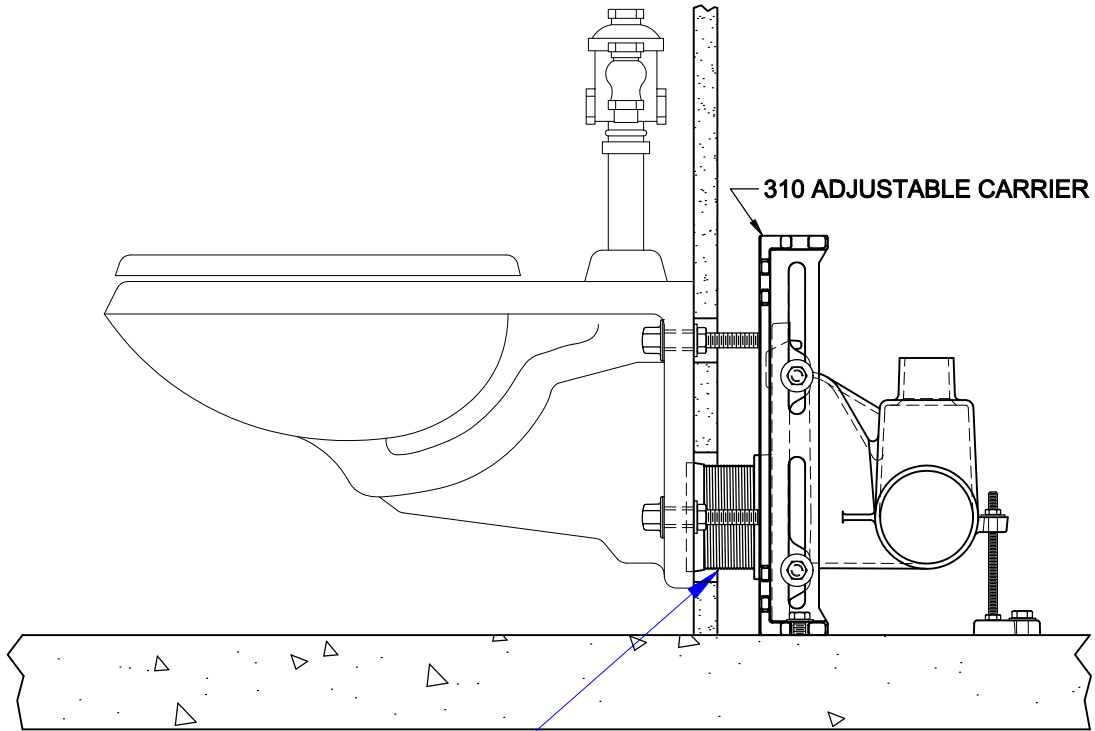

## COUPLING

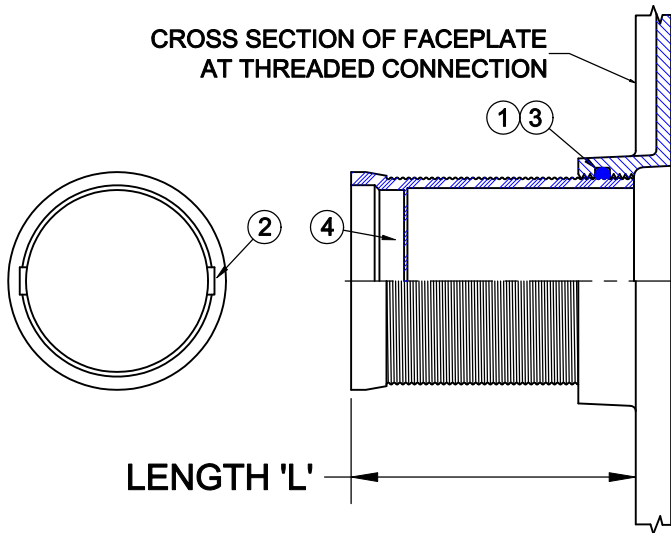

CATALOG NUMBER	L
P6	6
P14	14

- ① NEOPRENE O-RING SEAL
- ② LINEAR GROOVES FOR WRENCH ADJUSTMENT
- ③ RECESS FOR O-RING SEAL CONTAINMENT
- ④ INTEGRAL TEST CAP