

WALL HYDRANT



8600MT-175

3/4" MILD TEMP WALL HYDRANT WITH STRAIGHT INLET CONNECTION, BRONZE HEAD, BRASS OPERATING PARTS, OPERATING KEY AND SATIN FINISH NICKEL BRONZE BOX WITH HINGED LID.

Approval Date

Customer Approval

Job Location

Job Name

Wade Division / Tyler Pipe Assumes No Responsibility For Superseded or Voided Data
Dimensional Data (Inches/mm) are Subject to Manufacturers Tolerance and Change Without Notice.

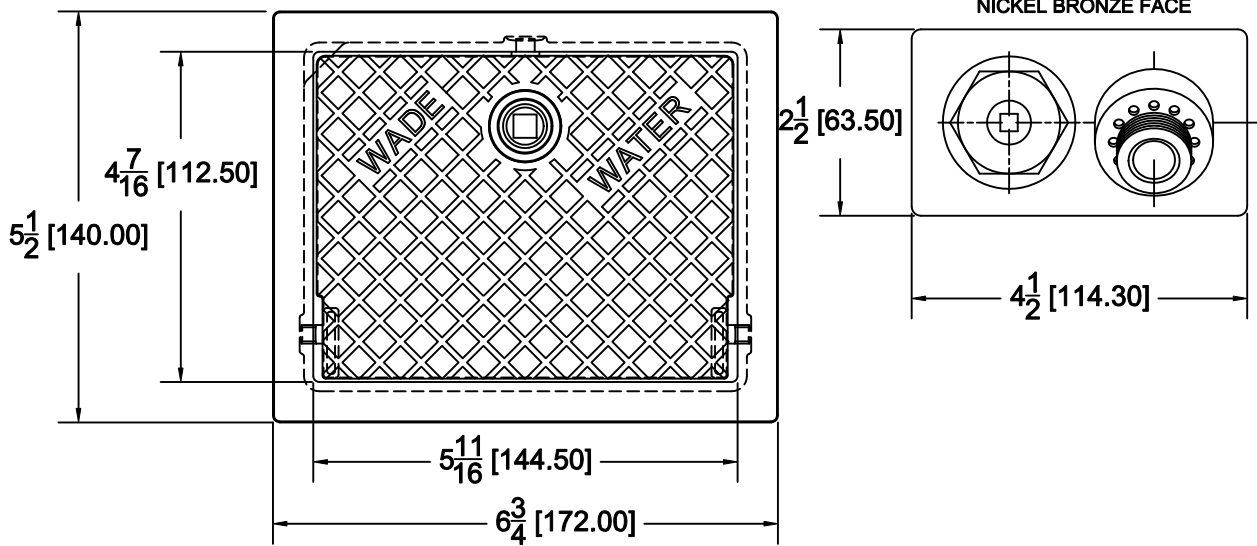
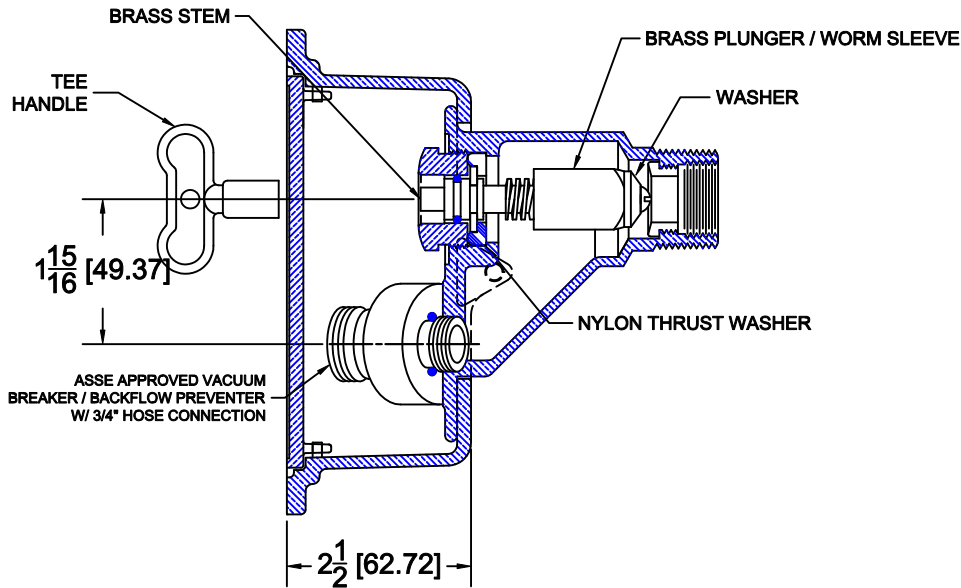

OPTIONS

Suffix	Description
87	COPPER SPEAT INLET CONNECTION
91	UNION ELBOW ASSEMBLY
92	KEY CYLINDER LOCK