



OPERATION, INSTALLATION AND MAINTENANCE INSTRUCTIONS 5000-5100 SERIES INTERCEPTORS

FEATURES

Wade 5000-5100 series interceptors are PDI (Plumbing & Drainage Institute) certified. All are equipped with a one-piece cover secured with machine screws. A soft elastomeric gasket is attached to the body of the interceptor to prevent odor from escaping. An air relief is provided to eliminate siphonage and each unit is furnished with a flow control device to insure it will perform to its rated capacity.

OPERATION

Waste water draining to the interceptor passes through the flow control device which regulates the velocity to a controlled rate. As water enters the interceptor, the baffle arrangement reduces turbulence to allow efficient separation. The grease, as separation occurs, floats to the top and is accumulated. The waste water, relieved of contaminants, continues to flow through the trap and into the drainage system. See diagram.

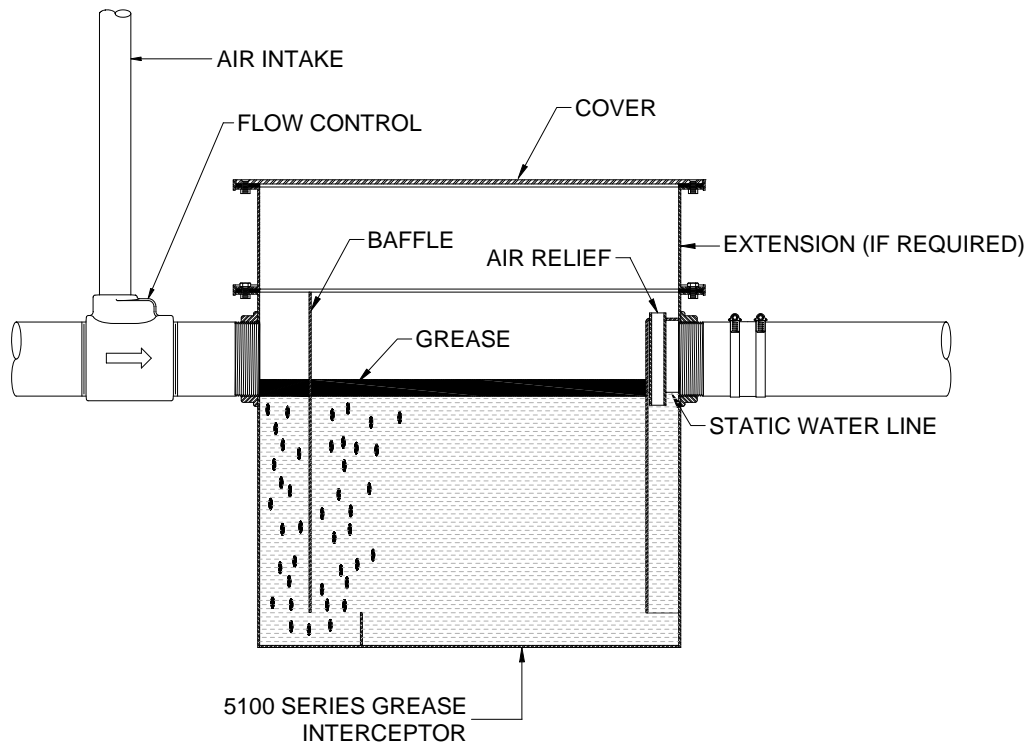



INSTALLATION

Install the interceptor as close as practical to the fixture(s) being served. Avoid installations where long runs of pipe (exceeding 25') are necessary to reach the interceptor. This precaution will preclude the possibility of grease becoming congealed in the pipe before it reaches the interceptor.

The unit may be placed on the floor, partially recessed in the floor, recessed with the top flush with the floor or encased below the floor in an appropriate housing to accommodate piping and structural considerations. Whatever the installation method, anticipate sufficient clearance to remove the cover and baffle for cleaning. Verify that no obstructions will be placed over the interceptor after installation. A minimum clearance equal the overall height of the interceptor (excluding any extension) is recommended.

Do not install the grease interceptor in a waste line from a garbage grinder. Garbage grinder waste must bypass the interceptor because the rapid accumulation of solid matter will significantly reduce the rated efficiency of the interceptor. In an application where solids will be present, a solids interceptor should be used.

A separate grease interceptor is recommended for each commercial dishwasher. The size is determined by the discharge rate of the dishwasher as stated by the manufacturer.

Placement of a grease interceptor in a high traffic area is an important concern. If the unit is to be installed flush with the floor, it is necessary to load rate the interceptor cover. The standard Wade interceptor is designed for pedestrian and light traffic only. If heavy loads are anticipated, the interceptor must be specified with an appropriate reinforced cover.

An extension is frequently used to increase the rough-in dimension from the inlet/outlet centerline to the finished floor. The extension anchor flange is not adequate to support the entire interceptor. For installations at flush-with-floor level, the interceptor chamber must rest on solid ground or a concrete pad. For upper floor installations, (suspended above the lower floor ceiling), the interceptor must be independently supported on hangers suitable to carry the entire weight.

A single interceptor serving multiple fixtures is recommended only where the fixtures are located close together. In these installations, each fixture should be individually trapped and vented.



FLOW CONTROL

The flow control device is designed with an integral orifice to achieve a predetermined optimum flow rate, thus eliminating turbulence and to regulate surges in the drainage line. The orifice opening in the flow control device is related to the size and flow rating of the grease interceptor. The standard orifice sizes are for gravity flow conditions where no pressure buildup is anticipated. If an interceptor is operating at maximum flow levels, a pressure head may develop, which may cause an overload condition.

Using the supplied flow control device is an important factor in the operation of the grease interceptor. The flow control device must be installed in the waste line upstream of the grease interceptor. Typically, the device is placed beyond the last connection from the fixture(s) and as close as possible to the underside of the lowest fixture. When two or more sinks or fixtures are combined and served by a single interceptor, a single flow control may be used.

The supplied flow control device must be properly vented to permit air to mix with the fluid entering the interceptor. Air facilitates the separation and, more importantly, is necessary to maintain optimum pressure, thereby maintaining the proper operating level within the interceptor chamber.

The flow control air intake may terminate under the sink drain board as high as possible, to prevent overflow. Another method is to terminate the vent outside the building. It is recommended that the installer check with the local plumbing code authority.

VENTING

Grease interceptors must have a vented waste, sized in accordance with code requirements for venting traps, to retain a water seal and to prevent siphoning.



INTERCEPTOR PERFORMANCE

Factors Affecting Grease Interceptor Performance

Velocity of Incoming Water

A higher velocity of water will contribute to turbulence and slow the grease separation process, thereby reducing efficiency. Installation of additional flow control devices at all the sources of flow may be required.

Grease to Water Ratio

Higher ratios of grease particles to the water will lower the efficiency of the interceptor – If high ratios of water to grease are anticipated, increase the size of the interceptor one or two units.

Detergents in the System

Degreasing agents or grease cutting detergents will break down the liquid grease into minute particles that can cause slower separation time, thus allowing these particles to pass through the interceptor. Increasing the size of the interceptor will allow longer retention rates and improve the efficiency.

Flow Capacity

If maximum recommended flow rates are exceeded, the efficiency of the interceptor will be decreased. Either install additional flow control devices at all sources of flow, or install a larger interceptor.

Specific Gravity of Filtrates

Grease has a lower specific gravity than water and will separate and rise to the surface quickly. If the waste water has food particles or solids having a higher specific gravity than water, these filtrates will accumulate at the bottom, eventually passing out of the interceptor. If high concentrations of solids are anticipated, the installation of a solids interceptor is recommended.

Installation Location

The interceptor should be located as close as possible to the source of grease. Piping to the interceptor could become clogged if the liquid cools prior entering the interceptor.

MAINTENANCE

General Considerations

Design and installation are key factors in the operation of a grease interceptor; however, without a disciplined maintenance program, efficiency and performance can be adversely affected. If adequate maintenance is not performed, excessive grease buildup will occur until the water laden with grease passes directly through the unit. Regardless of design efficiency or installation, grease interceptors perform only as well as the maintenance schedule allows.

Cleaning (5000 and 5100 Series)

The frequency of cleaning is determined by the use load factor and the capacity of the installed interceptor. An ideal cleaning cycle can be established after the unit has been in operation for several weeks. A logical cleaning schedule is normally determined by checking the unit after a normal shift, or following a period of peak usage. Grease removal intervals may vary from once a week to once in several weeks. Never clean an interceptor during a time when customers are present, as the offensive odors may develop inside the interceptor. Cleaning can easily be performed by following the steps listed:

1. Loosen and remove the fasteners securing the cover to the interceptor body.
2. Gently pry the cover from the body being careful not to damage the gasket seal.
3. With the cover removed, skin the grease from the inside and place in a disposable container. Never dispose of the contents in any part of the plumbing system.
4. Remove the baffle assembly and sediment basket (if so equipped) and clean.
5. Remove in accumulated solids from the bottom.
6. Replace internal components and secure the cover.
7. Periodic inspections of the flow control orifice are suggested.

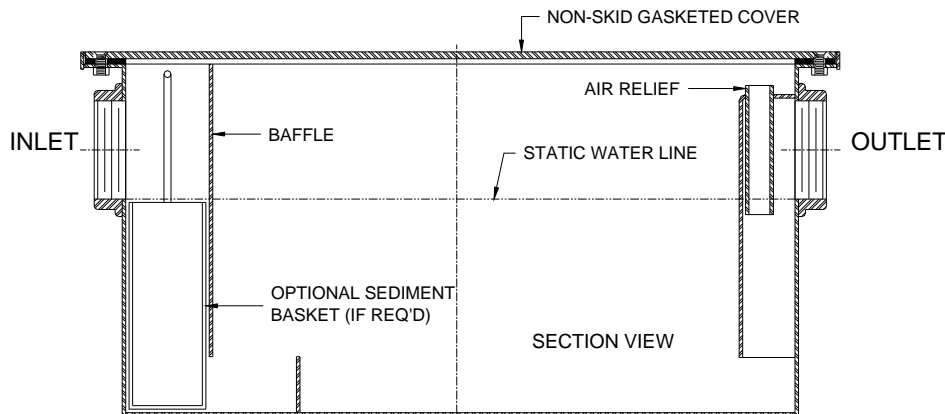

Cleaning (5100-JCX Series) Semi-Automatic Interceptor

To assist in the maintenance and cleaning process, Wade offers a unit incorporating a top draw-off port for grease removal. The cover has an accumulating hood to capture the liquid grease and funnel into the draw off port. Cleaning can easily be performed by following the steps listed:

1. The interceptor in normal use has the control valve off and the drain port plugged. When cleaning is required, run a full stream of hot water through a fixture serviced by the interceptor. This will liquefy the grease for extraction. A period of two minutes is required.
2. With the hot water supply shut off, turn the in-line closure valve to a fully closed position.
3. Remove the bronze plug from the cover and insert the hose fitting and flexible draw off hose, tightening the hose fitting securely. Place the end of the hose into a container suitable for disposal.
4. Turn the hot water supply back on back on and allow the water pressure to steadily force the liquefied grease through the hose. Caution: The liquid grease may be hot when exiting the draw-off hose; take care to keep the water flow as laminar as possible to prevent grease spilling.
5. Once grease is no longer visible at the discharge end, turn the water supply off. Properly dispose of the grease. Never dispose of the contents in any part of the plumbing system.
6. Remove the draw-off hose and fitting and replace the bronze plug.
7. Fully open the in-line control valve.
8. Periodic inspections of the flow control orifice are suggested.
9. A bi-annual inspection of the internals of the interceptor is recommended. Inspect and clean the baffle assembly and thoroughly clean the body of all solids and debris.

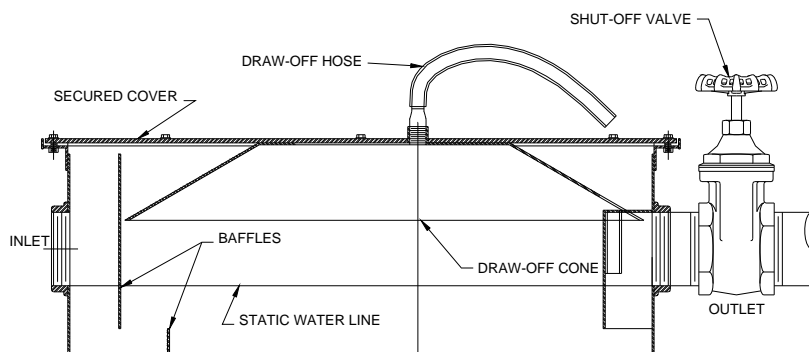



SIZING – PDI (Plumbing & Drainage Institute) Method

Sizing & Rating

Flow Rate (GPM)	4	7	10	15	20	25	35	50
Capacity (Lbs)	8	14	20	30	40	50	70	100

Procedure

The following example shows the steps for properly sizing a grease interceptor to suit requirements of specific fixtures.

Step	Formula	Example
1	Determine cubic content of fixture by multiplying length x width x depth	Sink 36" x 24" x 14" deep $36 \times 24 \times 14 = 12,096$ cubic in.
2	Determine capacity in gallons. 1 Gal = 231 cubic inches.	Contents in Gallons: $12,096 \div 231 = 52.36$ Gal
3	Determine actual drainage load. Fixtures are normally filled to 75% of capacity plus the items being washed displace about 25% of the fixture content, thus Actual Drainage Load = 75% of the fixture capacity	Actual Drainage Load $52.36 \text{ Gal} \times 0.75 = 39.3$ GPM
4	Determine flow rate and drainage period. Standard practice dictates a one minute drainage period. Where conditions permit, a two minute period is acceptable. Drainage period is the actual time required to completely drain the fixture. Flow Rate = Actual Drainage Load \div Drainage Period.	Calculate the flow rate for a one minute period: $39.3 \div 1 = 39.3$ GPM For a two minute period: $39.3 \div 2 = 19.65$ GPM
5	Select interceptor from the Sizing & Rating Table (above) which corresponds to the calculated flow rate. When the flow rate falls between two sizes, use the larger size.	For a one minute period: 50 GPM Interceptor Required For a two minute period: 20 GPM Interceptor Required

Alternate Sizing Method (Based on Drainage Fixture-Units)

Fixture Outlet (Trap Size)	Drainage Fixture Unit Value	GPM Equivalent	PDI Interceptor Size
1-1/4"	1	7.5	10
1-1/2"	2	15.0	15
2"	3	22.0	25
2-1/2"	4	30.0	35
3"	5	37.5	50
4"	6	45.0	50

TYPICAL INSTALLATIONS

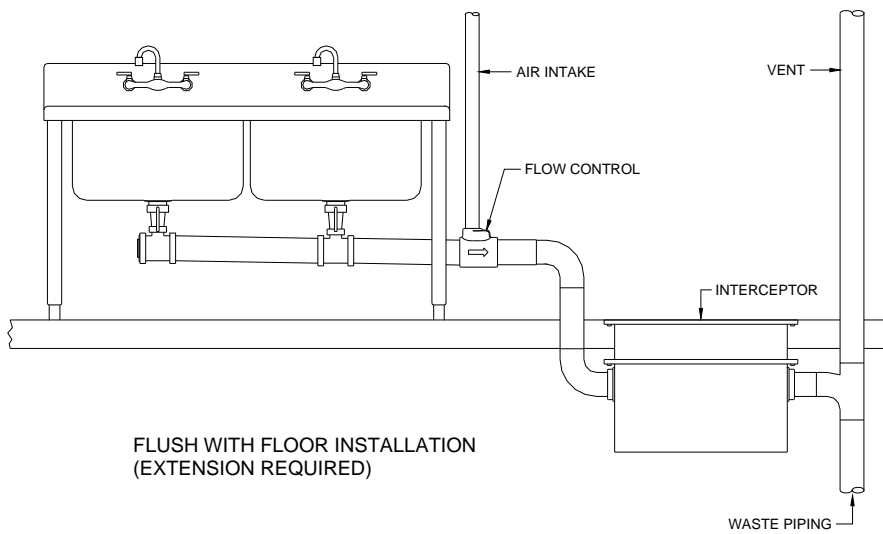
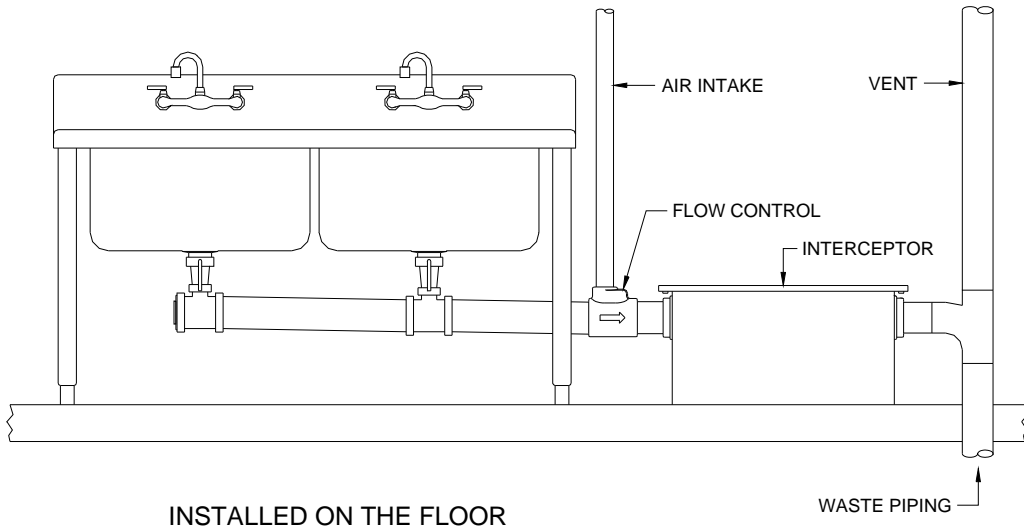



MATERIAL SPECIFICATIONS

Interceptor Body and Internals: Fabricated steel 10GA with acid resistant gray powder coating. Steel is low carbon (commercial quality). Conforms to ASTM A569.

Interceptor Cover: Rolled steel floor plate with raised lug pattern, 3/16" thick. Low carbon steel ASTM A786, Pattern number 4. Coated with acid resistant gray powder coat.

Flow Control Device: Body is cast iron ASTM A48-83, Class 25 with acid resistant epoxy coating.

Fasteners and Hardware: Steel alloy ANSI B18.3 UNC with oxide coating. 304 Stainless steel is optional.