

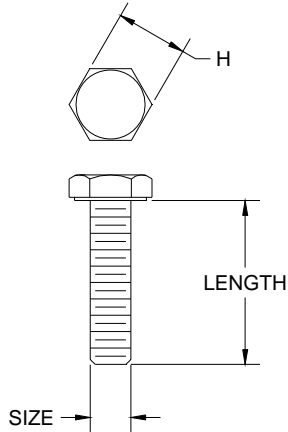

Adapter (Level Screw).....	18	Screws (cont'd)	
Anchor Lugs.....	28	Set Screws	
Bushings (Hex).....	22	Square Head.....	7
Carpet Marker.....	17	Hex Socket (Allen).....	8
Cap (Rubber).....	18	Slotted (Headless).....	8
Cotter Pins.....	17	Socket Head Cap Screws.....	9
Couplings.....	19,22	Round Head Machine Screws	
Covers.....	28	Slotted.....	6
Escutcheons.....	19	Phillips.....	6
Flat Head Self Tapping.....	12	Hex Key (Allen).....	7
Gaskets.....	30,31,32	Sealants.....	21
Hex Washer Head Cap Screws.....	2	Spring (Hinge).....	17
Hinge Pins.....	17	Standpipes.....	20
Hydrant Box Screw.....	17	Strip (Flat Bar).....	21
Labels & Decals.....	29	Thumb Screws.....	9
L-Bolts.....	10	Tie Rod.....	20
Lift Rings.....	28	Tools	27,28
Lock Devices.....	18	Truss Head Machine Screws.....	11
Lubricants.....	21	Threaded Rods.....	15
Pipe	21,22	U-Bolts.....	10
Pipe Fittings.....	22,23,24,25,26	Uprights.....	18
Perforated Sheet.....	21	Eye Bolts.....	11
Retaining Ring.....	15	Nuts	
Rod (Smooth).....	21	Hex.....	12
Screws		Hex Flange.....	12
Flat Head Machine Screws		Hex Cap.....	12
Hex Key (Allen).....	3	Wing.....	13
Slotted.....	4	U-Strut.....	13
Phillips.....	4	Bullet (Vandal Proof).....	14
Pin Allen (Security).....	5	Square.....	14
Spanner (Security).....	5	Bowl Saver.....	14
Torx.....	8	Spanner.....	17
Hex Head Cap Screws.....	2	Washers	
		Flat.....	16
		Finish.....	16
		Special.....	16
		Wire Cloth.....	21

FASTENERS

HEX HEAD CAP SCREWS



UPC (670610)	Part Number	Size	Length	H	Material
432272	BD-217H	¼-20NC	3/4	7/16	Zinc Plated Steel
263661	BD-219H	¼-20NC	1	7/16	Zinc Plated Steel
456087	BD-173H	¼-20NC	1 1/4	7/16	304 SS
456063	BD-171H	¼-20NC	1 1/2	7/16	304 SS
456070	BD-172H	¼-20NC	1 3/4	7/16	304 SS
468349	BD-177H	¼-20NC	2 1/4	7/16	304 SS
456094	BD-174H	¼-20NC	2 3/4	7/16	304 SS
226628	BD-234H	5/16-18NC	1	1/2	Zinc Plated Steel
263838	BD-408H	5/16-18NC	1 1/4	1/2	Zinc Chromate Steel
226635	BD-231H	5/16-18NC	1 1/2	1/2	Zinc Plated Steel
226642	BD-228H	3/8-16NC	3/4	9/16	Zinc Plated Steel
226659	BD-209H	3/8-16NC	1	9/16	Zinc Plated Steel
447870	BD-211H	3/8-16NC	1 1/4	9/16	Zinc Plated Steel
226772	BD-243NY	3/8-16NC	1 1/4	9/16	Nylon
444169	BD-241H	3/8-16NC	1 3/4	9/16	Zinc Plated Steel
263906	B-203H	½-13NC	1	3/4	Zinc Plated Steel
226871	B-214H	½-13NC	1 1/4	3/4	Zinc Plated Steel
263913	B-213H	½-13NC	1 1/2	3/4	Zinc Plated Steel
445234	B-216H	½-13NC	1 3/4	3/4	Zinc Plated Steel
226888	B-204H	½-13NC	2	3/4	Zinc Plated Steel
399346	B-207H	5/8-11NC	1/2	15/16	Zinc Plated Steel
263920	B-205H	5/8-11NC	1 1/4	15/16	Zinc Plated Steel
226895	B-207H	5/8-11NC	2 1/2	15/16	Zinc Plated Steel

HEX WASHER HEAD CAP SCREWS

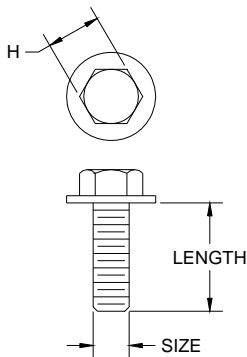

UPC (670610)	Part Number	Size	Length	H	Material
425779	BD-150HW	¼-20NC	3/4	3/8	304 SS
226598	BD-145HW	¼-20NC	1 1/16	5/16	304 SS
399377	BD-149HW	¼-20NC	1 1/4	3/8	Zinc Plated Steel
453260	BD-148HW	¼-20NC	1 1/2	3/8	Zinc Plated Steel
226611	BD-237HW	5/16-18NC	3/4	15/32	Zinc Plated Steel
432265	BD-234HW	5/16-18NC	1	15/32	Zinc Plated Steel
410027	BD-202HW	3/8-16NC	1/2	9/16	Zinc Plated Steel

FASTENERS

FLAT HEAD MACHINE SCREWS (HEX KEY) ALLEN

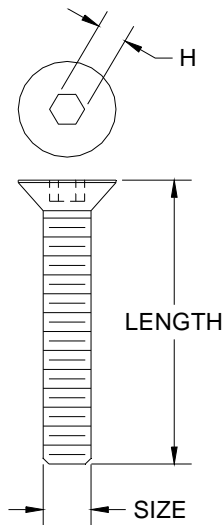

UPC (670610)	Part Number	Size	Length	H	Material
263548	BD-115A	10-24NC	3/8	3/32	304 SS
263531	BD-15A	10-24NC	3/8	3/32	Brass
226093	BD-122A	10-24NC	1/2	3/32	304 SS
280774	BD-22A	10-24NC	1/2	3/32	Brass
226147	BD-131A	10-24NC	3/4	3/32	304 SS
226147	BD-31A	10-24NC	3/4	3/32	Brass
226185	BD-531BA	10-24NC	3/4	3/32	Black Oxide Steel
226215	BD-114A	10-24NC	1	3/32	304 SS
263623	BD-14A	10-24NC	1	3/32	Brass
226246	BD-116A	10-24NC	1 1/4	3/32	304 SS
226284	BD-118A	10-24NC	1 1/2	3/32	304 SS
226512	BD-107A	1/4-20NC	1/2	5/32	304 SS
226796	BD-124A	1/4-20NC	3/4	5/32	304 SS
263869	BD-24A	1/4-20NC	3/4	5/32	Brass
226291	BD-133A	1/4-20NC	1	5/32	304 SS
263654	BD-33A	1/4-20NC	1	5/32	Brass
226352	BD-135A	1/4-20NC	1 1/4	5/32	304 SS
263678	BD-35A	1/4-20NC	1 1/4	5/32	Brass
226376	BD-120A	1/4-20NC	1 1/2	5/32	304 SS
263715	BD-20A	1/4-20NC	1 1/2	5/32	Brass
226451	BD-126A	1/4-20NC	1 3/4	5/32	304 SS
263739	BD-26A	1/4-20NC	1 3/4	5/32	Brass
444107	BD-159A	1/4-20NC	2	5/32	304 SS
444114	BD-160A	1/4-20NC	2 1/4	5/32	304 SS
226765	BD-215A	1/4-20NC	2 1/4	5/32	Zinc Plated Steel
444121	BD-161A	1/4-20NC	2 1/2	5/32	304 SS
226444	BD-136A	1/4-20NC	2 3/4	5/32	304 SS
444138	BD-162A	1/4-20NC	3	5/32	304 SS
444145	BD-163A	1/4-20NC	3 1/4	5/32	304 SS
444152	BD-164A	1/4-20NC	3 1/2	5/32	304 SS
444190	BD-165A	1/4-20NC	3 3/4	5/32	304 SS
226468	BD-111A	1/4-20NC	4	5/32	304 SS
263753	BD-11A	1/4-20NC	4	5/32	Brass
444206	BD-166A	1/4-20NC	4	5/32	304 SS
448860	BD-169A	1/4-20NC	4 1/4	5/32	304 SS
444213	BD-167A	1/4-20NC	5	5/32	304 SS
444220	BD-168A	1/4-20NC	5 1/2	5/32	304 SS
443933	BD-151A	5/16-18NC	3/4	3/16	304 SS
443933	BD-170A	5/16-18NC	1	3/16	304 SS
226666	BD-509BA	3/8-16NC	1	3/16	Black Oxide Steel
226697	BD-502BA	3/8-16NC	1 1/2	3/16	Black Oxide Steel
226758	BD-239A	3/8-16NC	3 1/2	7/32	Zinc Plated Steel

FASTENERS

FLAT HEAD MACHINE SCREWS SLOTTED

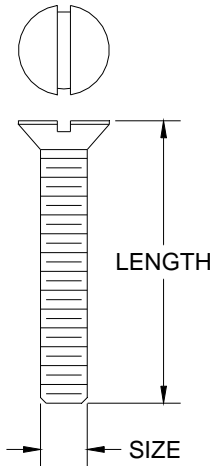

UPC (670610)	Part Number	Size	Length	Material
263524	BD-115	10-24NC	3/8	304 SS
263517	BD-15	10-24NC	3/8	Brass
263586	BD-122	10-24NC	1/2	304 SS
246763	BD-131	10-24NC	3/4	304 SS
246756	BD-31	10-24NC	3/4	Brass
246787	BD-114	10-24NC	1	304 SS
246770	BD-14	10-24NC	1	Brass
246794	BD-116	10-24NC	1 1/4	304 SS
263630	BD-16	10-24NC	1 1/4	Brass
226277	BD-118	10-24NC	1 1/2	304 SS
263579	BD-22	1/4-20NC	1/2	304 SS
246978	BD-124	1/4-20NC	3/4	304 SS
246800	BD-24	1/4-20NC	3/4	Brass
263814	BD-133	1/4-20NC	1	304 SS
246817	BD-33	1/4-20NC	1	Brass
263746	BD-126	1/4-20NC	1 3/4	304 SS
263722	BD-26	1/4-20NC	1 3/4	Brass
263777	BD-25	1/4-20NC	3 1/2	Brass
263760	BD-10	1/4-20NC	4 1/2	304 SS
226499	BD-170M	1/4-20NC	6	304 SS
263807	BD-123	5/16-18NC	3/4	304 SS
263791	BD-23	5/16-18NC	3/4	Brass
246824	BD-228	3/8-16NC	3/4	Zinc Plated Steel

FLAT HEAD MACHINE SCREWS PHILLIPS

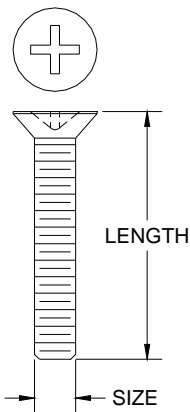

UPC (670610)	Part Number	Size	Length	Material
411628	BD-117P	8-32NC	3/8	304 SS
263555	BD-115P	10-24NC	3/8	304 SS
459279	BD-122P	10-24NC	1/2	304 SS
432227	BD-131P	10-24NC	3/4	304 SS
432234	BD-114P	10-24NC	1	304 SS
464167	BD-176P	10-24NC	2 1/2	304 SS

FASTENERS

FLAT HEAD MACHINE SCREWS PIN ALLEN (Security Screws)

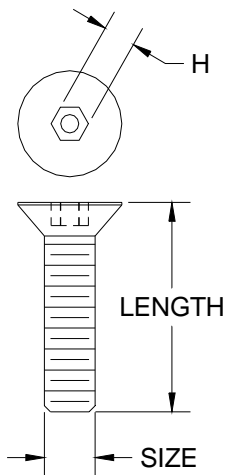

UPC (670610)	Part Number	Size	Length	H	Material
226109	BD-122PA	10-24NC	1/2	3/32	304 SS
226154	BD-131PA	10-24NC	3/4	3/32	304 SS
226222	BD-114PA	10-24NC	1	3/32	304 SS
408772	BD-116PA	10-24NC	1 1/4	3/32	304 SS
408789	BD-118PA	10-24NC	1 1/2	3/32	304 SS
226802	BD-124PA	1/4-20NC	3/4	5/32	304 SS
226314	BD-133PA	1/4-20NC	1	5/32	304 SS
226406	BD-120PA	1/4-20NC	1 1/2	5/32	304 SS
226390	BD-144PA	1/4-20NC	2	5/32	304 SS
354864	BD-146PA	1/4-20NC	2 1/4	5/32	304 SS
357032	BD-147PA	1/4-20NC	2 1/2	5/32	304 SS

FLAT HEAD MACHINE SCREWS SPANNER STYLE (Security Screws)

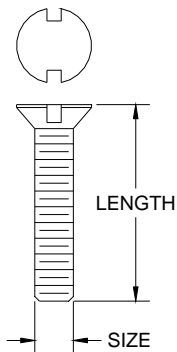

UPC (670610)	Part Number	Size	Length	Material
226116	BD-122SP	10-24NC	1/2	304 SS
226154	BD-131SP	10-24NC	3/4	304 SS
226253	BD-116SP	10-24NC	1 1/4	304 SS
226420	BD-120SP	1/4-20NC	1 1/2	304 SS
226604	BD-125SP	1/4-20NC	3	304 SS

FASTENERS

ROUND HEAD MACHINE SCREWS SLOTTED

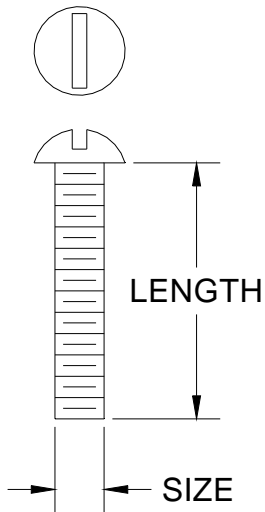

UPC (670610)	Part Number	Size	Length	Material
226086	BD-115R	10-24NC	3/8	304 SS
263562	BD-15R	10-24NC	3/8	Brass
263593	BD-122R	10-24NC	1/2	304 SS
226178	BD-31R	10-24NC	3/4	Brass
263616	BD-114R	10-24NC	1	304 SS
226208	BD-14R	10-24NC	1	Brass
226345	BD-101R	¼-20NC	1/2	Zinc Plated Steel
244332	BD-132R	¼-20NC	1	304 SS
226321	BD-32R	¼-20NC	1	Brass
226369	BD-283R	¼-20NC	1 1/4	Zinc Plated Steel
226437	BD-239R	¼-20NC	2	Zinc Plated Steel

ROUND HEAD MACHINE SCREWS PHILLIPS

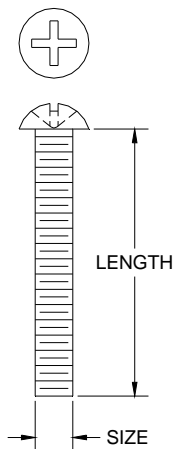

UPC (670610)	Part Number	Size	Length	Material
309284	BD-101RP	¼-20NC	1/2	Zinc Plated Steel
226383	BD-208RP	¼-20NC	1 3/4	Zinc Plated Steel

FASTENERS

ROUND HEAD MACHINE SCREWS (HEX KEY) ALLEN

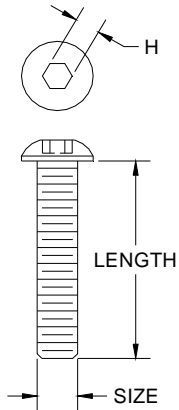

UPC (670610)	Part Number	Size	Length	H	Material
226185	BD-531BA	10-24NC	3/4	1/8	Black Oxide Steel
444008	BD-158RA	1/4-20NC	1 1/4	5/32	304 SS
443995	BD-157RA	1/4-20NC	1 1/2	5/32	304 SS
443988	BD-156RA	1/4-20NC	1 3/4	5/32	304 SS
443971	BD-155RA	1/4-20NC	2	5/32	304 SS
443964	BD-154RA	1/4-20NC	2 1/4	5/32	304 SS
443957	BD-153RA	1/4-20NC	2 1/2	5/32	304 SS
443940	BD-152RA	1/4-20NC	2 3/4	5/32	304 SS

SQUARE HEAD SET SCREWS (CUP POINT)

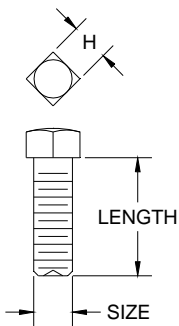

UPC (670610)	Part Number	Size	Length	H	Material
226505	S-201SQ	1/4-20NC	1/2	1/4	Zinc Chromate Steel
226529	S-202SQ	1/4-20NC	3/4	1/4	Zinc Chromate Steel
226536	S-209SQ	1/4-20NC	1 1/4	1/4	Zinc Chromate Steel
226543	S-210SQ	1/4-20NC	2	1/4	Zinc Chromate Steel
263838	S-203SQ	5/16-18NC	1 1/2	5/16	Zinc Chromate Steel
263883	S-204SQ	3/8-16NC	3/4	5/16	Zinc Chromate Steel
263840	S-205SQ	3/8-16NC	1	5/16	Zinc Chromate Steel
226857	S-205SQ	3/8-16NC	1 1/2	5/16	Zinc Chromate Steel

FASTENERS

HEX SOCKET SET SCREWS (CUP POINT)

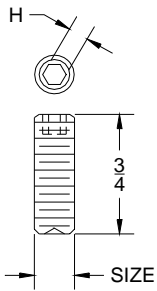

UPC (670610)	Part Number	Size	Length	H	Material
226574	S-106A	1/4-20NC	1/2	1/8	304 SS
226567	S-501A	1/4-20NC	1/2	1/8	Black Oxide Steel
410010	S-203A	3/8-16NC	1/2	3/16	Zinc Plated Steel

SLOTTED HEADLESS SET SCREWS (FLAT POINT)

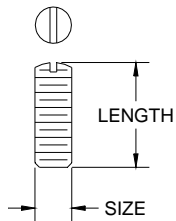

UPC (670610)	Part Number	Size	Length	Material
226550	S-206S	1/4-20NC	1/2	Zinc Plated Steel
226475	S-212S	1/4-20NC	4	Zinc Plated Steel
226482	S-213S	1/4-20NC	6	Zinc Plated Steel

FLAT HEAD MACHINE SCREWS TORX

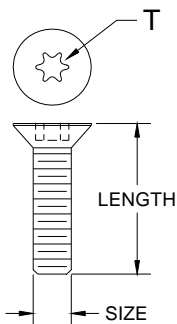

UPC (670610)	Part Number	Size	Length	T	Material
299769	BD-114X	10-24NC	1	T20	304 SS
301196	BD-133X	1/4-20NC	1	T27	304 SS
226130	BD-127X	1/4-20NC	1 1/4	T27	304 SS
299523	BD-120X	1/4-20NC	1 1/2	T27	304 SS

FASTENERS

SOCKET HEAD CAP SCREWS (HEX KEY) ALLEN

UPC (670610)	Part Number	Size	Length	H	Material
263845	BD-302SA	3/8-16NC	1/2	5/16	Chrome Plated Steel

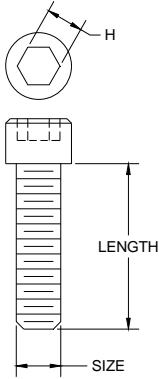

THUMB SCREWS

UPC (670610)	Part Number	Size	Length	Material
263647	BD-230S	1/4-20NC	3/4	Zinc Plated Steel
226307	BD-233S	1/4-20NC	1 1/4	Zinc Plated Steel
263692	BD-220S	1/4-20NC	1 1/2	Zinc Plated Steel
226413	BD-218S	1/4-20NC	2	Zinc Plated Steel

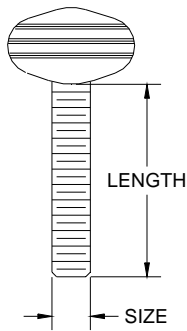

FASTENERS

L-BOLTS

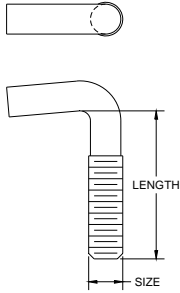

UPC (670610)	Part Number	Size	Length	Material
464174	BD-431HK	1/4-20NC	3 1/2	Zinc Plated Steel
226710	BD-405HK	3/8-16NC	1 5/8	Zinc Plated Steel
226734	BD-429HK	3/8-16NC	2 3/4	Zinc Plated Steel
226741	BD-430HK	3/8-16NC	4	Zinc Plated Steel
226819	BD-412HK	3/8-16NC	6 1/2	Zinc Plated Steel

U-BOLTS

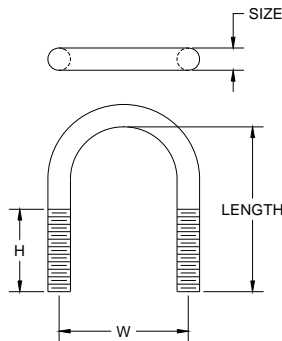

UPC (670610)	Part Number	Size	Length	H	W	Material
226864	S-212U	3/8-16NC	2 3/4	1 3/8	2 1/8	Zinc Plated Steel

U-BOLTS (Square Bent)

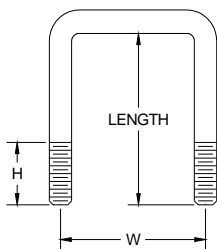

UPC (670610)	Part Number	Size	Length	H	W	Material
409991	S-213U	3/8-16NC	2 3/4	1	2 7/16	Zinc Plated Steel

FASTENERS

TRUSS HEAD MACHINE SCREWS (Slotted)

UPC (670610)	Part Number	Size	Length	H	Material
226338	B-235T	1/4-20NC	1 1/4	9/16	Zinc Plated Steel

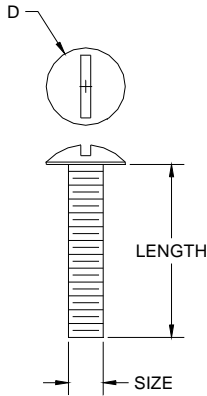

EYE BOLT MACHINE SCREWS

UPC (670610)	Part Number	Size	Length	D	H	Style
226833	BD-439E	1/4-20NC	2 1/2	9/16	1 3/4	A
427957	BD-418E	5/16-18NC	4	5/16	2 1/2	B
226826	BD-403E	3/8-16NC	3 3/4	5/16	2 1/2	B

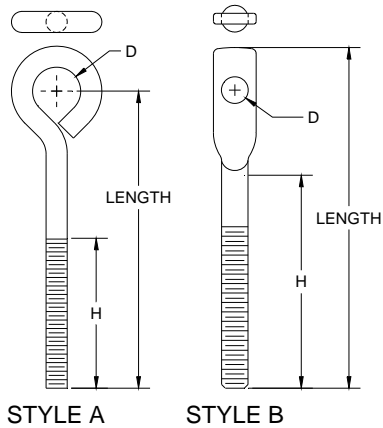

Material: Zinc Plated Steel

FASTENERS

FLAT HEAD DRILL POINT SELF-TAPPING SCREWS (Phillips)

UPC (670610)	Part Number	Size	Length	H	Material
226192	BD-131SDP	10	3/4	3/8	Zinc Plated Steel

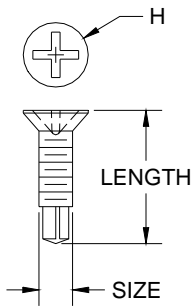

HEX NUTS

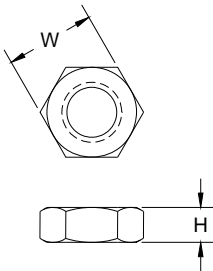

UPC (670610)	Part Number	Size	W	H	Material
226932	N-207	1/4-20NC	7/16	7/32	Zinc Plated Steel
427988	N-213	5/16-18NC	1/2	3/16	Zinc Plated Steel
226970	N-206	3/8-16NC	9/16	7/32	Zinc Plated Steel
263937	ND-2	3/8-16NC	9/16	21/64	Brass
227007	N-205	1/2-13NC	3/4	7/16	Zinc Plated Steel
227045	N-204	5/8-11NC	15/16	3/8	Zinc Plated Steel
410881	N-212	3/4-10NC	1 1/8	27/64	Zinc Plated Steel
226918	N-417	7/8-9NC	1 5/16	3/4	Zinc Plated Steel

HEX WASHER NUTS

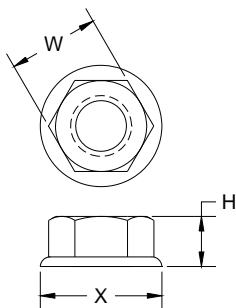

UPC (670610)	Part Number	Size	W	H	X	Material
410348	NW-207	1/4-20NC	7/16	15/64	37/64	Zinc Plated Steel
420538	NW-208	5/16-18NC	1/2	9/31	11/16	Zinc Plated Steel
410331	NW-206	3/8-16NC	9/16	11/32	3/4	Zinc Plated Steel
430100	NW-204	5/8-11NC	15/16	9/16	1 1/4	Zinc Plated Steel
430117	NW-212	3/4-10NC	1 1/8	5/8	1 1/2	Zinc Plated Steel

FASTENERS

HEX CAP NUTS

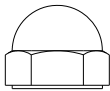
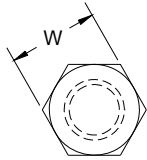

UPC (670610)	Part Number	Size	W	Material
226925	N-303	1/4-20NC	7/16	Chrome Plated Steel
432661	N-313	5/16-18NC	1/2	Chrome Plated Steel
226956	N-302	3/8-16NC	9/16	Chrome Plated Steel
227021	N-301	5/8-11NC	15/16	Chrome Plated Steel
410898	N-304	3/4-10NC	1 1/8	Chrome Plated Steel

WING NUTS

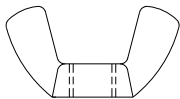

UPC (670610)	Part Number	Size	Material
226901	N-416	1/4-20NC	Zinc Plated Steel
427964	N-418	5/16-18NC	Zinc Plated Steel
226987	N-411	3/8-16NC	Zinc Plated Steel

U-STRUT NUTS

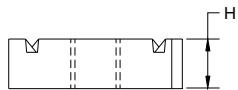
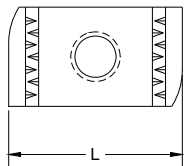

UPC (670610)	Part Number	Size	L	H	Material
227076	N-512S	3/8-16NC	1 5/16	3/8	Zinc Plated Steel
427964	N-513S	5/8-11NC	1 5/16	1/2	Zinc Plated Steel

FASTENERS

BULLET CAP NUTS (VANDAL PROOF) SPANNER STYLE

UPC (670610)	Part Number	Size	Material
226963	N-302-M3	3/8-16NC	Chrome Plated Brass
227854	N-301-M3	5/8-11NC	Chrome Plated Brass

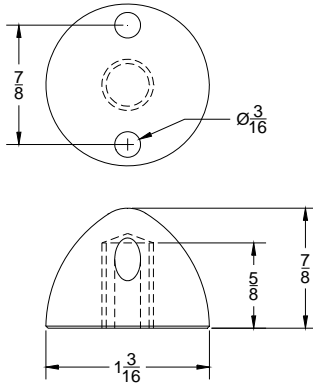

SQUARE NUTS

UPC (670610)	Part Number	Size	W	H	Material
309307	N-208	1/4-20NC	7/16	7/32	Zinc Plated Steel
226949	N-209	5/16-18NC	9/16	17/64	Zinc Plated Steel

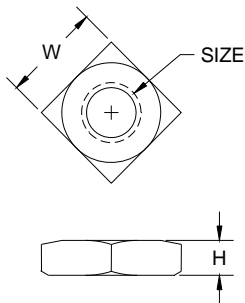

Bowl Saver Nut

UPC (670610)	Part Number	Size	Material
227052	N-210	5/8-11NC	Zinc Plated Steel

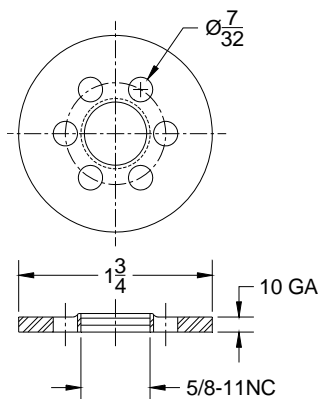

FASTENERS

THREADED RODS

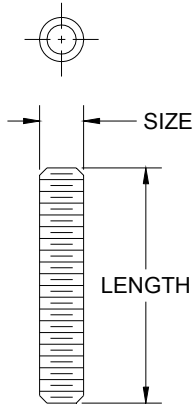

UPC (670610)	Part Number	Size	Length	Material
227930	R-1	1/4-20NC	6	Zinc Plated Steel
227854	R-2	1/4-20NC	8	Zinc Plated Steel
228042	R-27	1/4-20NC	10	Zinc Plated Steel
228105	RD-3	5/16-18NC	4 3/4	Zinc Plated Steel
420545	R-6	5/16-18NC	8	Zinc Plated Steel
432692	R-51	5/16-18NC	10	Zinc Plated Steel
432708	R-52	5/16-18NC	14	Zinc Plated Steel
432715	R-53	5/16-18NC	18	Zinc Plated Steel
432722	R-54	5/16-18NC	26	Zinc Plated Steel
455417	R-43	3/8-16NC	2	Zinc Plated Steel
227915	R-9	3/8-16NC	3	Zinc Plated Steel
228172	R-39	3/8-16NC	4	Zinc Plated Steel
227878	R-4	3/8-16NC	6	Zinc Plated Steel
227861	R-3	3/8-16NC	8	Zinc Plated Steel
227885	R-8	3/8-16NC	10	Zinc Plated Steel
227946	R-16	3/8-16NC	12	Zinc Plated Steel
228080	R-31	3/8-16NC	14	Zinc Plated Steel
228097	R-32	3/8-16NC	16	Zinc Plated Steel
228103	R-33	3/8-16NC	18	Zinc Plated Steel
228110	R-34	3/8-16NC	20	Zinc Plated Steel
228127	R-35	3/8-16NC	22	Zinc Plated Steel
228134	R-36	3/8-16NC	24	Zinc Plated Steel
228141	R-37	3/8-16NC	26	Zinc Plated Steel
228158	R-38	1/2-13NC	2	Zinc Plated Steel
228073	R-30	1/2-13NC	3	Zinc Plated Steel
302605	R-41	1/2-13NC	8	Zinc Plated Steel
227960	R-19	1/2-13NC	14	Zinc Plated Steel
264354	RD-1	5/8-11NC	4 3/4	Zinc Plated Steel
227977	R-20	5/8-11NC	5	Zinc Plated Steel
227892	R-5	5/8-11NC	6	Zinc Plated Steel
227908	R-7	5/8-11NC	8	Zinc Plated Steel
227922	R-14	5/8-11NC	10	Zinc Plated Steel
455776	R-14HS	5/8-11NC	10	Chromate Steel
227939	R-15	5/8-11NC	12	Zinc Plated Steel
408741	R-45	5/8-11NC	14	Zinc Plated Steel
227953	R-18	5/8-11NC	15	Zinc Plated Steel
408758	R-46	5/8-11NC	17	Zinc Plated Steel
227984	R-21	5/8-11NC	18 1/4	Zinc Plated Steel
227991	R-22	5/8-11NC	22	Zinc Plated Steel
228004	R-23	5/8-11NC	24	Zinc Plated Steel
408765	R-47	5/8-11NC	27	Zinc Plated Steel
354963	R-42	5/8-11NC	28	Zinc Plated Steel
410850	R-48	3/4-10NC	10	Zinc Plated Steel
410867	R-49	3/4-10NC	14	Zinc Plated Steel
410874	R-50	3/4-10NC	17	Zinc Plated Steel
228189	R-40	7/8-9NC	12	Zinc Plated Steel

FASTENERS

FLAT WASHERS

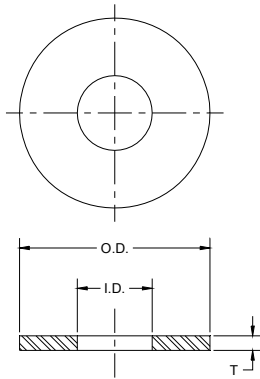

UPC (670610)	Part Number	Screw Size	I.D.	O.D.	T	Material
227090	W-213	10	13/64	1 1/4	16GA	Zinc Plated Steel
227106	W-207	1/4	5/16	3/4	16GA	Zinc Plated Steel
427971	W-208	5/16	3/8	7/8	16GA	Zinc Plated Steel
432685	W-508	5/16	3/8	7/8	16GA	Plastic
227144	W-203	3/8	7/16	1	14GA	Zinc Plated Steel
227137	W-303	3/8	7/16	1	14GA	304 S/S
227120	W-503	3/8	7/16	1	16GA	Plastic
446477	W-203SAE	3/8	13/32	13/16	14GA	Zinc Plated Steel
432296	W-202	3/8	7/16	1 1/4	14GA	Zinc Plated Steel
227151	W-210	1/2	9/16	1 3/8	12GA	Zinc Plated Steel
444657	W-212	1/2	9/16	1 3/8	7GA	Zinc Plated Steel
227212	W-201	5/8	11/16	1 3/4	10GA	Zinc Plated Steel
227199	W-302	5/8	11/16	1 1/4	16GA	304 S/S
227199	W-301	5/8	11/16	1 3/4	10GA	304 S/S
227175	W-501	5/8	11/16	1 3/4	16GA	Plastic
410829	W-214	3/4	13/16	2	9GA	Zinc Plated Steel
410843	W-504	3/4	13/16	2	16GA	Plastic

FINISH WASHERS

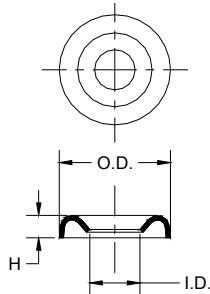

UPC (670610)	Part Number	Screw Size	I.D.	O.D.	H	Material
227113	W-312	1/4	11/32	25/32	5/32	304 S/S
227106	W-313	1/4	11/32	25/32	5/32	Brass

SPECIAL WASHERS

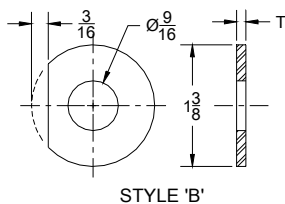
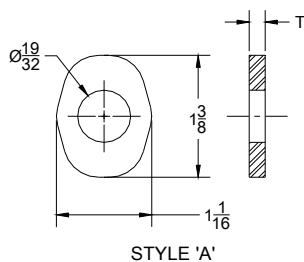

UPC (670610)	Part Number	Screw Size	T	Style	Material
432463	W-211	1/2	7GA	A	Zinc Plated Steel
227106	W-313	1/2	12GA	B	Zinc Plated Steel

FASTENERS

SPANNER NUT

MD-155
670610 264972
Material: Chrome Plated Brass

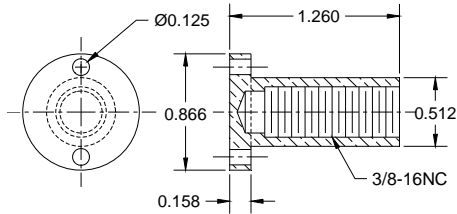

CARPET MARKER

FBD-125
670610 243298
Material: Aluminum

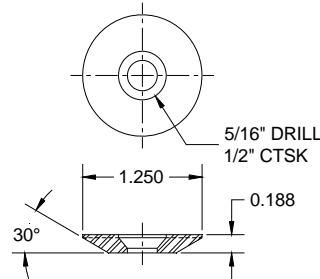

HYDRANT BOX SCREW

BD-6S
670610 226727
Material: Brass

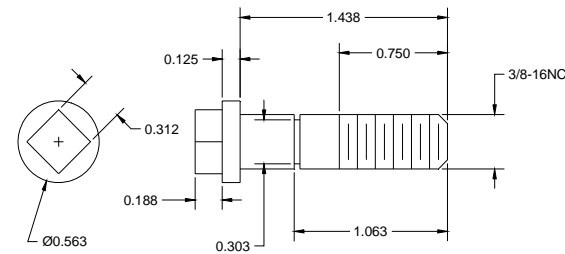

COTTER PINS

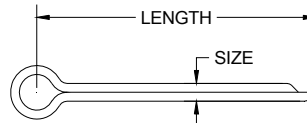

UPC	Part Number	Size	L	Material
670610	CD-1	1/8	2	Brass
227229				

RETAINING RING

HY-1
670610 228875
Material: Stainless Steel

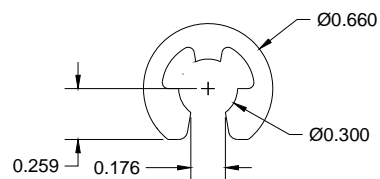

HINGE PIN

MD-50
670610 246947
Material: Zinc Plated Steel

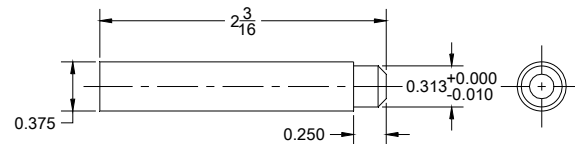

HINGE PIN

MD-1405
670610 230458
Material: Zinc Plated Steel

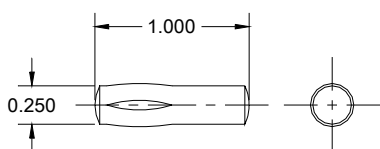

HINGE SPRING

MD-51
670610 246954
Material: Stainless Steel
Used With MD-50 Hinge Pin

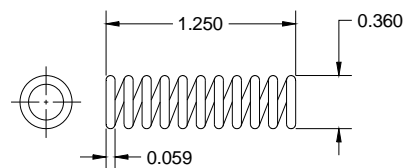

MISCELLANEOUS HARDWARE

RUBBER CAP

M-1
670610 228677

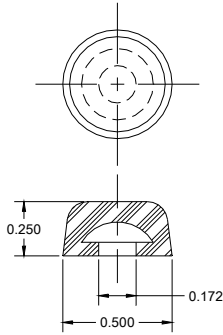

LEVELING SCREW ADAPTER

M-2-1
670610 228707
Material: Zinc Plated Steel

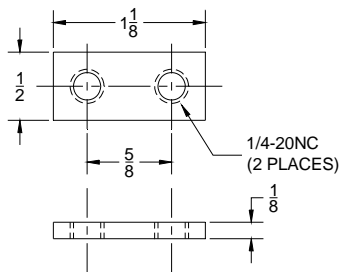

LOCKING DEVICE

M-25-1
670610 228783
Material: Zinc Plated Steel

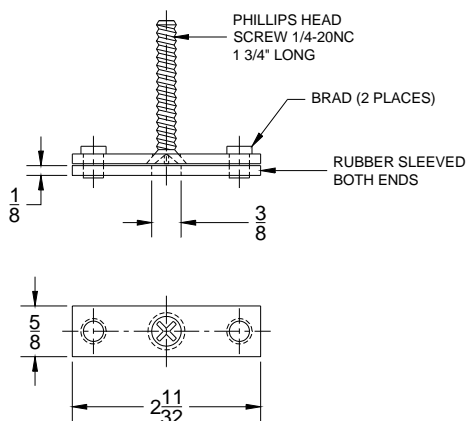

SQUARE UPRIGHTS

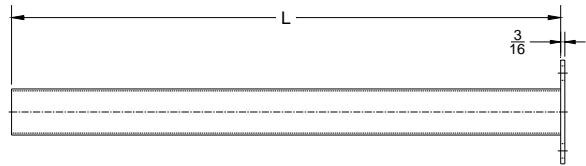

UPC 670610	Part Number	Size	L	Material
423829	PU-22-36	2X2	36	Steel
406419	PU-22-47	2x2	47	Steel
406655	PU-22-60	2x2	60	Steel
468257	PU-22x72	2x2	72	Steel

ROUND UPRIGHTS

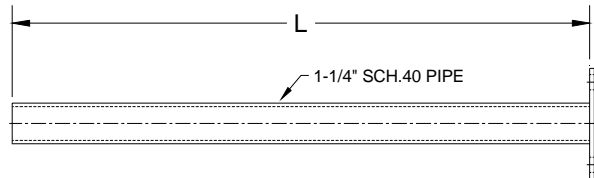

UPC 670610	Part Number	Size	L	Material
227434	PU-2F	1 1/4	36	Steel
227410	PU-1F	1 1/4	47	Steel
227427	PU-7F	1 1/4	60	Steel
468240	PU-8F	1 1/4	72	Steel

UNISTRUT UPRIGHTS

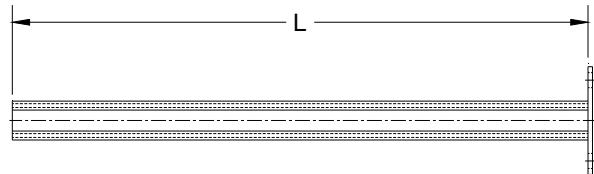

UPC 670610	Part Number	L	Material
227380	PU-9-36	36	Steel
227397	PU-10-47	47	Steel
227403	PU-11-60	60	Steel

MISCELLANEOUS HARDWARE

COUPLING

M-12A
670610 228738
Material: PVC

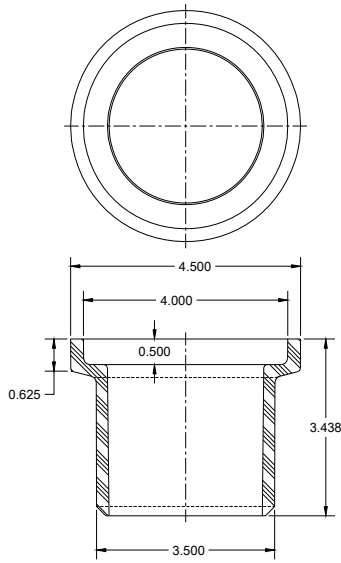

COUPLING

M-12D
670610 228745
Material: PVC

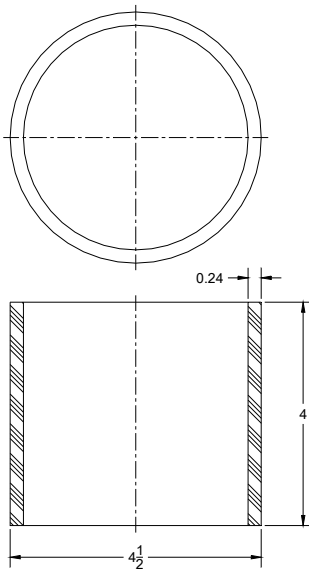

ESCUTCHEONS

Material: Chrome Plated Steel

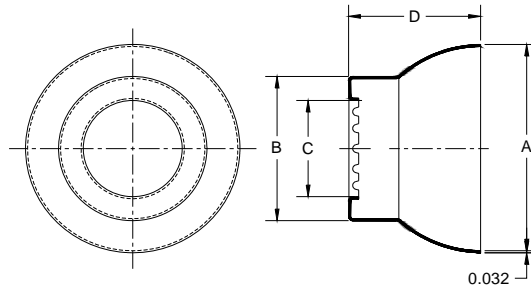

UPC 670610	Part Number	A	B	C	D
229773	MD-323	3 1/2	2 1/2	1.671	2
453567	2400-PES	3 1/4	2 1/4	1.500	2

ESCUTCHEON

2400-PFS
670610 453574
Material: Chrome Plated Steel

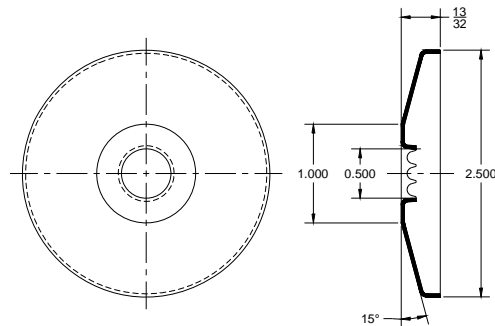

MISCELLANEOUS HARDWARE

BWV FLAPPER

M-39

670610 228837

Material: Neoprene

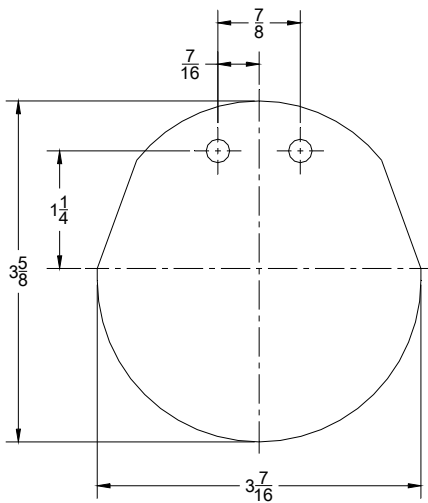

SPLIT RING HANGER

M-92

670610 230243

Material: Copper Plated Malleable Iron

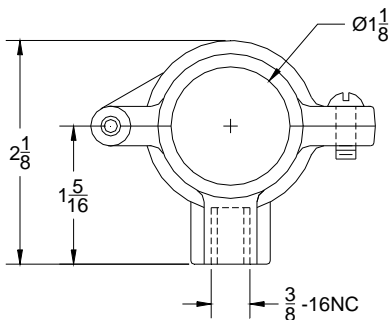

STANDPIPES

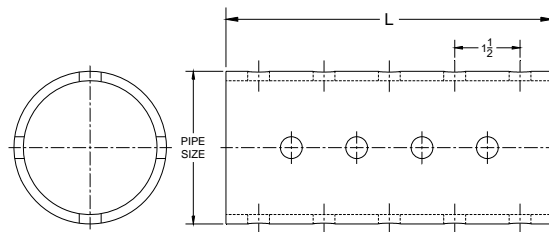

STYLE A

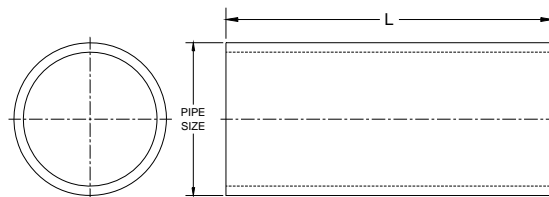

STYLE B

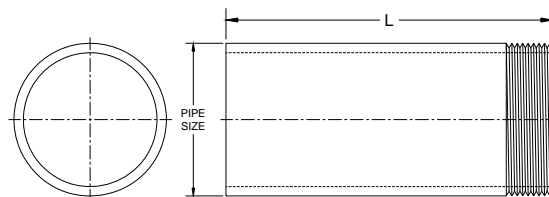

STYLE C

UPC 670610	Part Number	Pipe Size	L	Style	MATERIAL
229773	MD-597	3	7 1/2	A	Galv. Steel
230298	MD-597	3	7 1/2	A	Galv. Steel
229681	MD-504	3	9	C	PVC
230304	MD-97	3	8	B	PVC
230298	MD-97	3	8	B	Brass
264750	MD-4	3	12 1/2	A	Brass
230281	MD-96	3	10 1/2	B	Brass
429616	SD31/2	3 1/2	4 1/2	C	PVC
230274	MD-95	6	4 3/4	C	PVC
230342	MD-99	6	7	B	PVC
230335	MD-99	6	7	B	Brass
230229	MD-88	6	8		PVC
230182	MD-81	8	4 3/4	C	PVC

TIE ROD

TR-1

670610 227441

Material: Hot Rolled Steel Rod

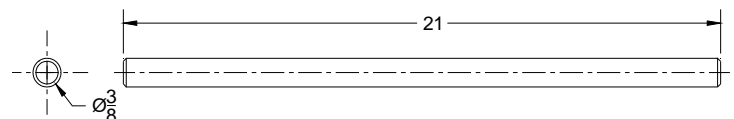

MISCELLANEOUS HARDWARE

PIPE (Per/Ft)

(Sch.40 unless otherwise specified)

UPC 670610	Part Number	Pipe Size	MATERIAL
229735	MD-505-2	2	Galv. Steel
229698	MD-504-3	3	Galv. Steel
229742	MD-505-4	4	Galv. Steel
264781	MD-505-5	5	Galv. Steel
229766	MD-505-6	6	Galv. Steel
229780	MD-505-8	8	Galv. Steel

UPC 670610	Part Number	Pipe Size	MATERIAL
229704	MD-5-2	2	Brass
229933	MD-5-3	3	Brass
229711	MD-5-4	4	Brass
264767	MD-5-5	5	Brass
264774	MD-5-6	6	Brass

UPC 670610	Part Number	Pipe Size	MATERIAL
230144	MD-65-2	2	Steel
229728	MD-5-8	8	Steel
230496	MD-1109	8	304 S/S

UPC 670610	Part Number	Pipe Size	MATERIAL
230311	MD-98-3	3	PVC – Sch 40
230328	MD-98-4	4	PVC – Sch 40
229759	MD-505A	4	ABS – Sch 40
229940	MD-26-6	6	PVC – Sch 80
243694	MD-81-8	8	PVC – Sch 80

ANGLE (Per/Ft)

UPC 670610	Part Number	Size	MATERIAL
230212	MD-86	1x1x1/8	Steel
264880	MD-15	1x1x1/8	Brass
230366	MD-186	1x1x1/8	304 S/S
229926	MD-21		Steel

ROD (Smooth)

UPC 670610	Part Number	Size	Length	MATERIAL
229988	MD-29	1/8	6	Brass
230007	MD-31	1/8	Per/Ft	Brass
229957	MD-27	1/4	Per/Ft	Steel
229964	MD-127	1/4	Per/Ft	304 S/S
230250	MD-93	1/4	Per/Ft	Aluminum
229971	MD-28	3/8	Per/Ft	Steel
227458	TR-2	3/8	Per/Ft	Steel

STRIP (Flat Bar)

UPC 670610	Part Number	Width	T	Length	MATERIAL
230120	MD-59	1/2	1/8	Per/Ft	Brass
265016	MD-89	1	1/4	Per/Ft	Brass
230236	MD-90	1	1/4	Per/Ft	304 S/S
265009	MD-85	1	16GA	Per/Ft	Aluminum
230205	MD-84	1	1/4	Per/Ft	Steel

WIRE CLOTH (Per/Ft)

UPC 670610	Part Number	MESH SIZE	WIRE DIA.	MATERIAL
227682	MD-2SFT	16	.018	Brass
229629	MD-102SFT	16	.018	304 S/S

PERFORATED SHEET (Per/Ft)

UPC 670610	Part Number	MESH SIZE	PERF. DIA.	MATERIAL
229445	FBD-136	11 GA	1/2	304 S/S
229407	FBD-131	14 GA	3/16	304 S/S

LUBRICANTS & SEALANTS

UPC 670610	Part Number	MATERIAL
228844	LD-2	Gasket Adhesive 3M EC-847
228851	LD-3	Sealant Devcon Siltite 100
228868	LD-4	Sealant Permatex No. 2
383024	LD-5	Lubricant – Petroleum Jelly

MISCELLANEOUS HARDWARE

ELBOWS

(Thread x Thread)

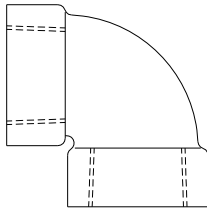

UPC 670610	Part Number	Size	MATERIAL
229889	MD-10	1/2	Galv. Malleable
230489	MD-1108	1/2	304 S/S
228943	LRD-3	1 1/2	Malleable
228950	LRD-3	2	Malleable

PIPE NIPPLES

(Thread x Thread)

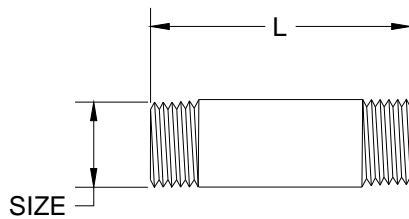

UPC 670610	Part Number	Size	L	MATERIAL
303923	MD-37	1/2	2	Galv. Stl.
230465	MD-1106	1/2	2 1/2	304 S/S
230472	MD-1107	1/2	3	304 S/S
426943	MD-1108	1/2	3 1/2	304 S/S
422075	MD-1105	1/2	5	304 S/S
230021	MD-34	1/2	5 1/16	Galv. Stl.
230168	MD-68	1/2	5 5/16	Galv. Stl.
422082	MD-1104	1/2	6	304 S/S
230038	MD-35	1/2	6 1/2	Galv. Stl.
230175	MD-69	1/2	8 5/16	Galv. Stl.
229131	LRD-25	1	Close	Brass
229018	LRD14	1 1/2	Close	Galv. Stl.
229025	LRD14	2	Close	Galv. Stl.
229032	LRD14	3	Close	Galv. Stl.
229056	LRD14	4	Close	Galv. Stl.

PIPE COUPLINGS

(Thread x Thread)

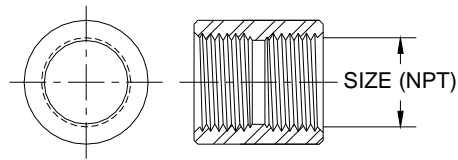

UPC 670610	Part Number	Size	MATERIAL
230373	MD-196	1/2	304 S/S
230137	MD-63	2	Galv. Stl.

HEX BUSHINGS

(Thread x Thread)

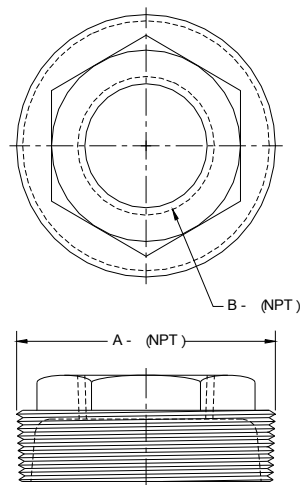

UPC 670610	Part Number	Pipe Size (A x B)	MATERIAL
229872	MD-9	1 x 1 1/2	Galv. Malleable
264798	MD-7	1 1/2 x 1 1/4	Galv. Malleable
264804	MD-7	2 x 1	Galv. Malleable
264811	MD-7	2 x 1 1/4	Galv. Malleable
229810	MD-7	2 x 1 1/2	Galv. Malleable
264828	MD-7	2 1/2 x 2	Galv. Malleable
229827	MD-7	3 x 2	Galv. Malleable
264835	MD-7	3 x 2 1/2	Galv. Malleable
229834	MD-7	3 1/2 x 3	Galv. Malleable
229841	MD-7	4 x 3	Galv. Malleable
264859	MD-7	4 x 3 1/2	Galv. Malleable
264866	MD-7	5 x 3	Galv. Malleable
264866	MD-7	5 x 4	Galv. Malleable
229858	MD-7	6 x 4	Galv. Malleable
229865	MD-7	6 x 5	Galv. Malleable

MISCELLANEOUS HARDWARE

PIPE CAPS (Threaded)

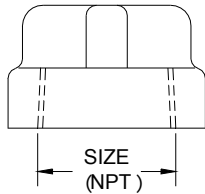

UPC 670610	Part Number	Size (NPT)	MATERIAL
229100	LRD-22	1	Brass

STREET ELBOWS (Thread x Thread)

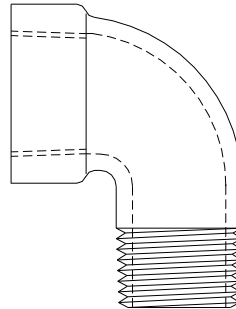

UPC 670610	Part Number	Size	MATERIAL
246862	LRD-6	1 1/4	Brass
246879	LRD-306	1 1/4	Chrome Plated
247159	LRD-7	1 1/2	Brass
228967	LRD-307	1 1/2	Chrome Plated
229001	LRD-13	1 1/2	Galvanized

HOSE ADAPTER (Thread x Hose Barb)

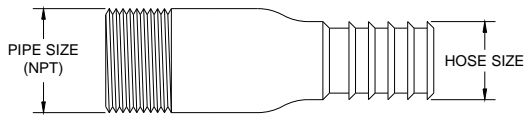

UPC 670610	Part Number	Size (NPT)	Hose Size	MATERIAL
229094	LRD-21	1	1	Brass

GATE VALVES (Bronze w/ Wheel Handle)

(Bronze w/ Wheel Handle)

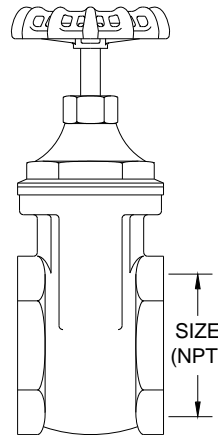

UPC 670610	Part Number	Size
229179	LRD-29-2	2
229186	LRD-29-3	3
229193	LRD-29-4	4

HEX NUTS

(Galvanized Malleable Iron)

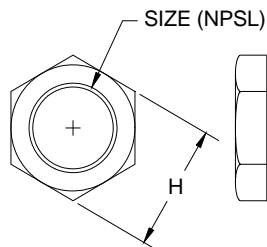

UPC 670610	Part Number	Size	H
229162	LRD-28	3/4	1.43
229124	LRD-24	1	1.75
211242	595-NT	1 1/4	2.21

MISCELLANEOUS HARDWARE

ELBOWS

(NPSL Thread x Ground Joint)
w/ Slip Joint Nut

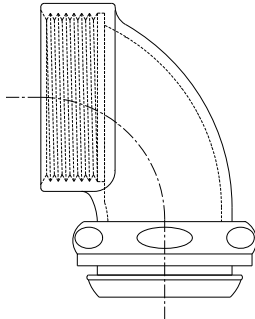

UPC 670610	Part Number	Size	MATERIAL
		1 1/2	Chrome Plated

SLIP JOINT NUTS

(1-1/2" NPSL Thread x Tube O.D.)

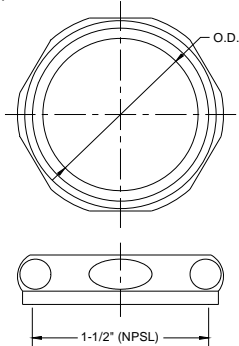

UPC 670610	Part Number	Tube O.D.	MATERIAL
246909	LRD-10	1 1/4	Brass
246916	LRD-310	1 1/4	Chrome Plated
246923	LRD-11	1 1/2	Brass
228981	LRD-311	1 1/2	Chrome Plated
453635	2400-PN	1 1/2	Chrome Plated

SLIP JOINT ELBOWS

(Thread x Plain End)

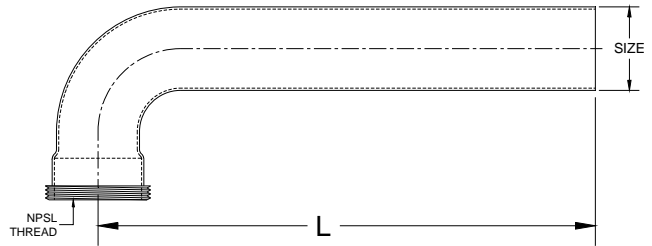

UPC 670610	Part Number	Size	L	MATERIAL
247142	LRD-8	1 1/4	6	Brass
246886	LRD-308	1 1/4	6	Chrome Plated
246893	LRD-9	1 1/2	7	Brass
228974	LRD-309	1 1/2	9	Chrome Plated

SLIP JOINT ELBOWS

(Slip Joint x Plain End)

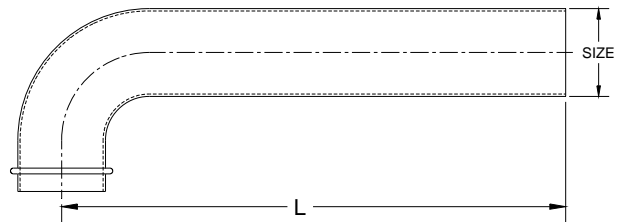

UPC 670610	Part Number	Size	L	MATERIAL
453536	2400-PEB	1 1/2	9	Chrome Plated

TUBING

UPC 670610	Part Number	Size	Length	MATERIAL
229049	LRD-15	1 1/2	6	Brass
229155	LRD-27	2	6	Brass

MISCELLANEOUS HARDWARE

COMPRESSION ELBOW

2400-PCE

1/2 NPT X 3/8 NPS

670610 453543

Material: Chrome Plated Brass

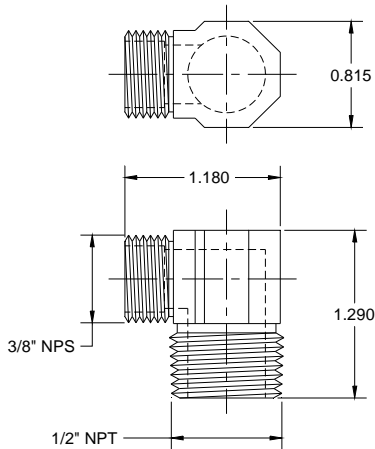

COMPRESSION ADAPTER

2400-PCA

Material: Chrome Plated Brass

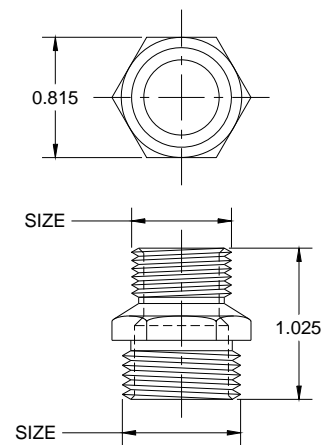

TUBING TAILPIECE

M-92

670610 230243

Material: Chrome Plated Brass

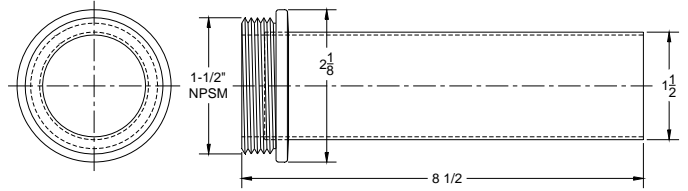

CLEANOUT PLUG

2400-PCP

3/4" NPS

670610 453611

Material: Chrome Plated Brass

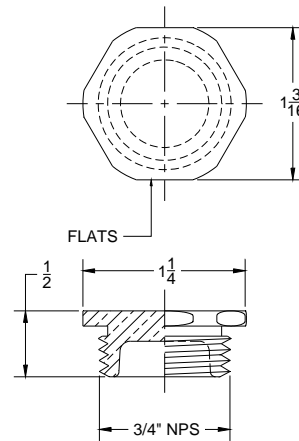

COMPRESSION NUT

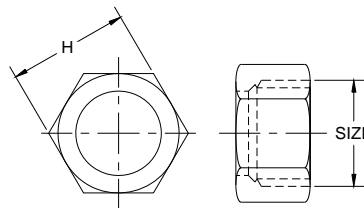

UPC	Part Number	Size
670610		
453598	2400-PCA	1/2 X 3/8
469124	2400-PCB	1/2 X 1/2

UPC	Part Number	Size	H	MATERIAL
670610				
454052	2400-CN2	3/8	.74	Chrome Plated
454045	2400-CN1	1/2	.90	Chrome Plated

MISCELLANEOUS HARDWARE

COMPRESSION FERRULE

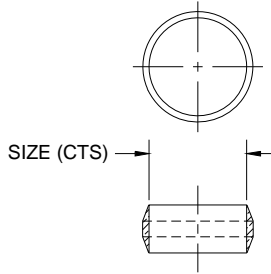

UPC 670610	Part Number	Size	MATERIAL
454076	2400-CF2	3/8	Brass
454069	2400-CF1	1/2	Brass

PIPE NIPPLES (for Lavatory Carriers)

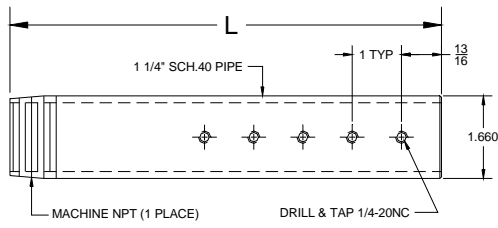

STYLE 'A'

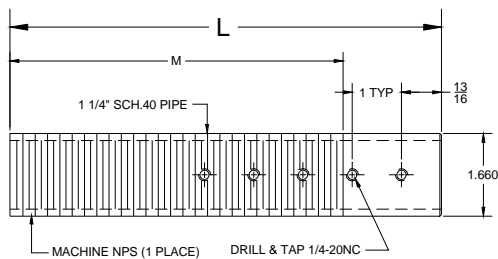

STYLE 'B'

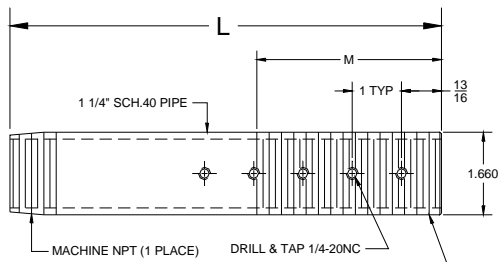

STYLE 'C'

FLEX SUPPLY

2400-PTF
670610 453666
Size: 3/8" NPS
Material: Stainless Steel Flex

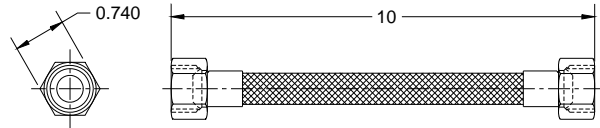

RIGID SUPPLY

2400-PTR
670610 453673
Material: Type M Copper (Chrome Plated)

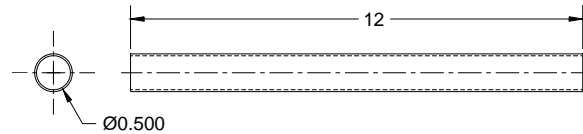

PIPE NIPPLES (CHART)

UPC 670610	Part Number	L	M	Style	Qty of D&T Holes
227236	PN-1	6 3/4	-	A	3
227243	PN-2	6 3/4	3 3/4	B	3
227250	PN-3	3 3/4	-	A	2
227267	PN-4	3 3/4	1 3/4	C	2
227274	PN-5	5 1/2	-	B	2
227281	PN-6	5 1/2	1 1/2	B	2
227298	PN-7	6 3/4	3 1/4	C	3
227328	PN-8	11	-	A	2
263951	PN-9	13	-	A	5
263968	PN-10	13	1 3/4	C	2
227335	PN-11	8 3/4	-	A	5
227342	PN-12	1/4	3 3/4	c	5
432746	PN-13	4	-	A	2
227359	PN-14	15	12	C	3
227366	PN-15	8 3/4	6 3/4	B	5
227373	PN-16	11	9 1/2	C	3
227304	PN-17	5 1/2	-	A	2
227311	PN-18	5 1/2	2	C	2
304463	PN-19	13	-	A	5
448440*	PN-20	3 3/4	-	All Thr'd	-

* 1-1/2" NPSL (All Thread Nipple) for 800 Series Trap Standards

MISCELLANEOUS HARDWARE

COUPLING WRENCH

M-16
670610 455554
Material: Painted Steel

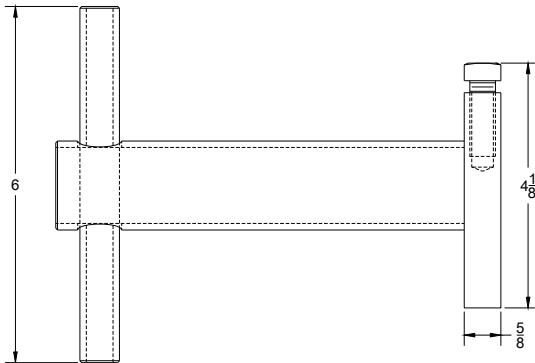

UPC 670610	Part Number	H	Style
444084	MD-1504A	5/32	Allen
230434	MD-1503PA	5/32	Pin Allen
228936	MD-1505A	3/16	Allen
475767	MD-1506PA	1/8	Pin Allen

WRENCH - SPANNER (Fresh Air Inlet)

MD-56
670610 230113
Material: Plated Steel

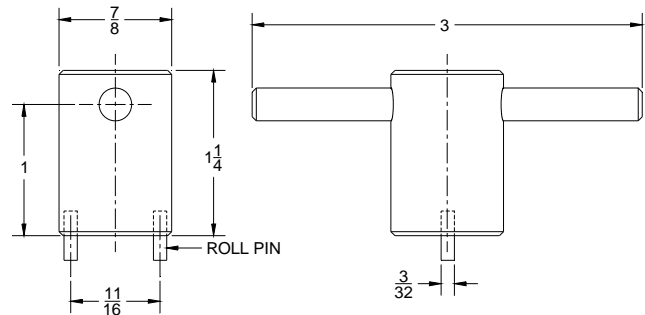

BULLET NUT WRENCH

M-5
670610 228684
Material: Plated Steel

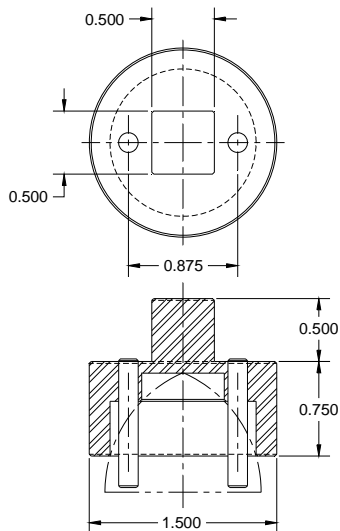

WRENCH - SPANNER (Cleanouts)

MD-38
670610 230076
Material: Plated Steel

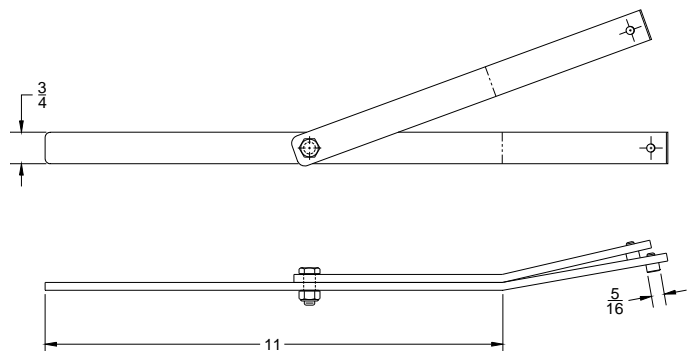

WRENCH - ALLEN

MISCELLANEOUS HARDWARE

COUPLING WRENCH

M-15

670610 455554

Material: Painted Steel

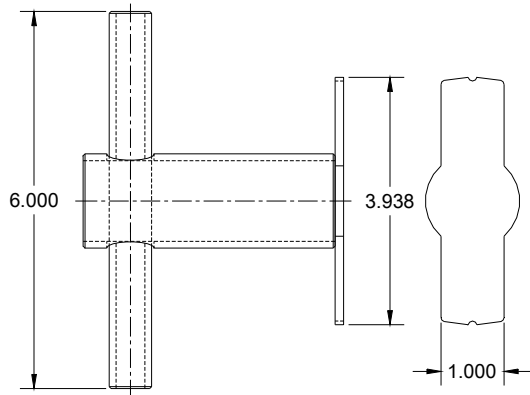

SQUARE COVER

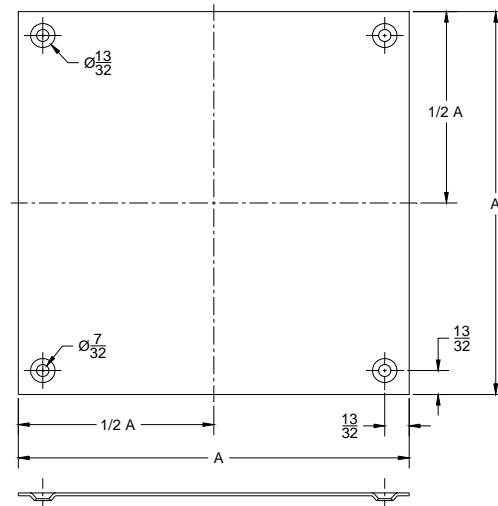

UPC 670610	Part Number	A Size	MATERIAL
229902	MD-116	6 1/2	430 S/S
281238	MD-117	8 1/2	430 S/S
280804	MD-18	9 1/2	Brass
281221	MD-118	9 1/2	430 S/S
280811	MD-120	10 9/16	430 S/S
280828	MD-125	11 7/8	430 S/S

ANCHOR LUGS

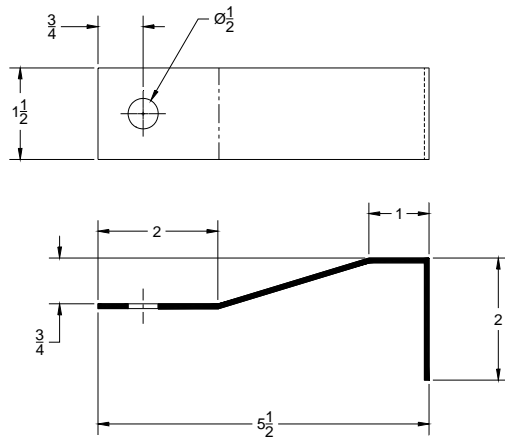

UPC 670610	Part Number	MATERIAL
229896	MD-13	Steel
433101	MD13	304 S/S

LIFT RINGS (Plated Steel)

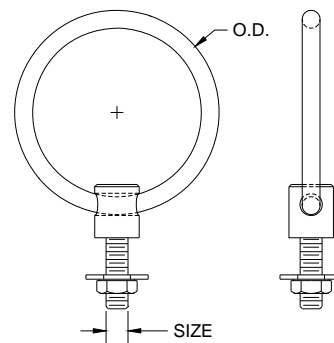

UPC 670610	Part Number	O.D.	Size
228912	LRD-1	1 1/4	3/8" NPT
230267	MD-94	1 7/8	1/4-20 NC
228936	LRD-2	27/8	5/16-18 NC

LABELS & DECALS

Flow Rate Decal
670610 229612
DD-5

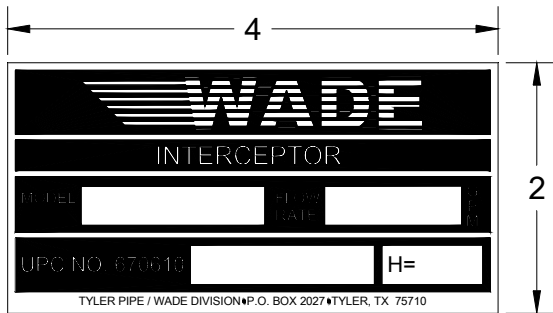

PDI Certification Decal
(Interceptors)
670610 229599
DD-3



Instruction Decal
670610 229582
DD-2

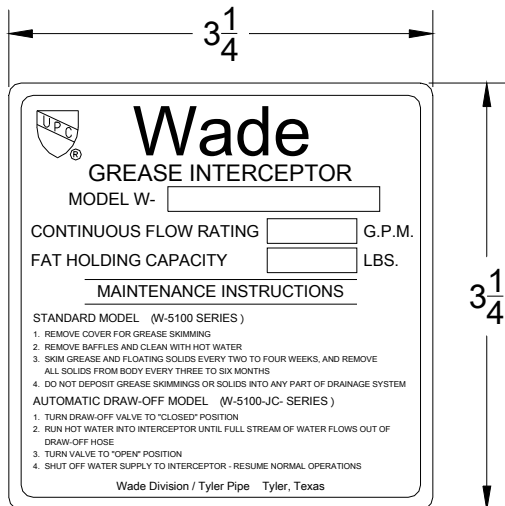

PDI Certification Decal
(Water Hammer Arrestors)
670610 229612
DD-4



GASKETS

O-rings

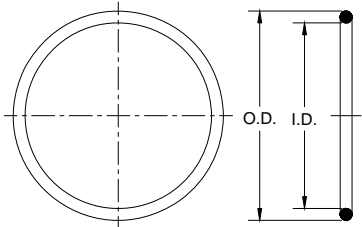

UPC 670610	Part Number	O.D.	I.D.
453581	2400-PG2	.905	.745
453604	2400-PG2	1.905	1.745
264286	G7-2		
432197	GD-60	2.781	2.469
410577	GD-56	4.449	4.055
407515	GD-53	4.913	4.362
432630	GD-62	6.938	6.375
432623	GD-63	10.813	10.281

Flat Gaskets

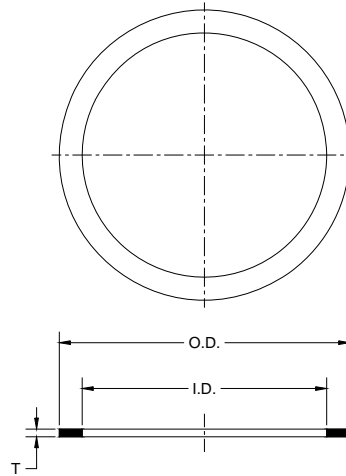

UPC 670610	Part Number	O.D.	I.D.	T
432326	GD-61	1.250	.438	.125
227793	GD-52	1.781	1.493	.156
448518	G-67	2.450	1.825	.125
448051	G-66	3.813	2.625	.125
430087	G-5	5.000	4.475	.275
420583	GD-57	5.130	3.500	.3752
407522	GD-54	5.250	4.500	.188
459767	GD-68	5.500	4.063	.125

Push-On Gaskets

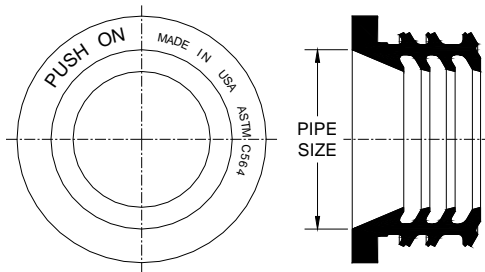

UPC 670610	Part Number	Pipe Size
396406	GD-39-2	2"
396413	GD-39-3	3"
396420	GD-39-4	4"
396802	GD-39-5	5"
396437	GD-39-6	6"
420798*	GD-10-6	6"

*Sch.40 IPS Pipe Size Only

Bowl Gasket 670610 246855

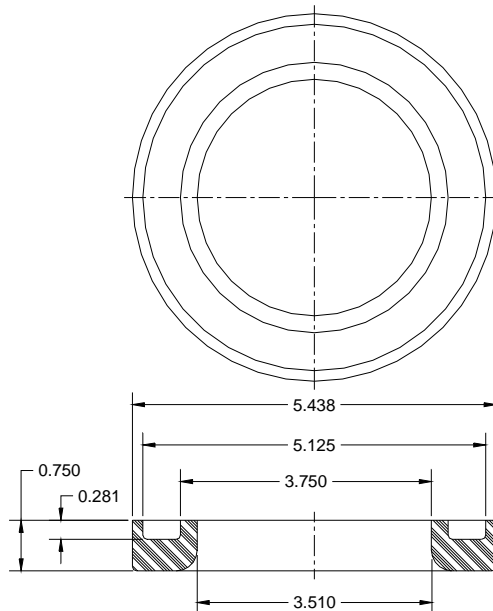

GASKETS

Flange Gaskets

Coupling Gasket
 670610 227670
 G-2A

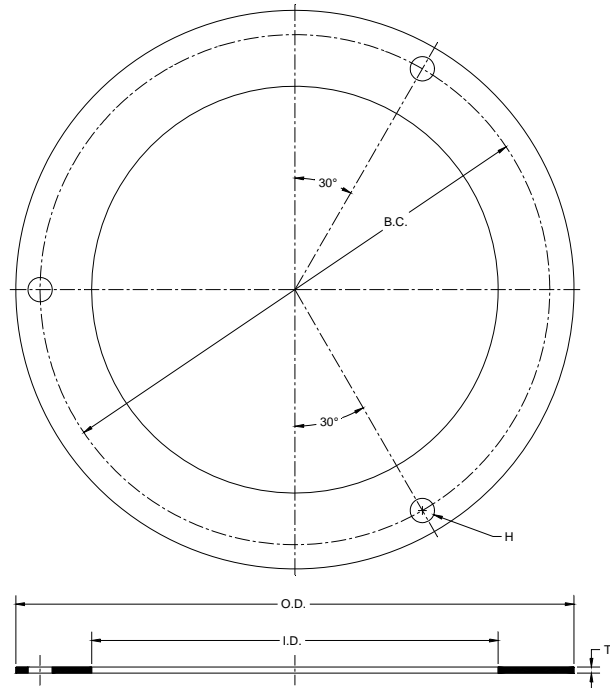
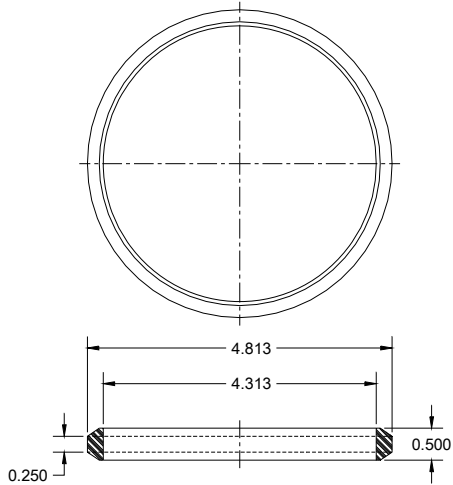

Faceplate Gasket
 670610 227809
 G-4-3

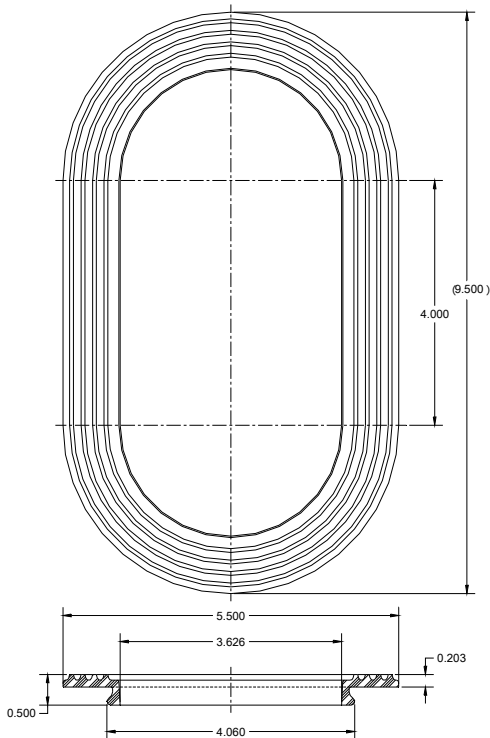

UPC 670610	Part Number	O.D.	I.D.	B.C.	T
	GD-54	7.625	5.813	6.500	.063
	227526	8.500	7.000	7.875	.125
	227724	11.500	8.375	1.0500	.125
	227694	15.750	11.661	13.750	.125

GASKETS

Expansion Joint Gaskets

Coupling Gasket

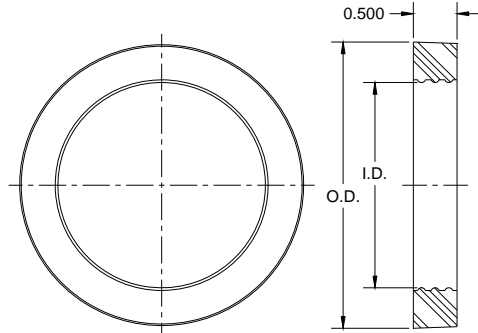

UPC 670610	Part Number	O.D.	I.D.
428411	GD-3A-2	3.313	2.375
227465	GD-3A-3	4.375	3.500
227472	GD-3A-4	5.375	4.500
227694	GD-3A-5	15.750	11.661