

HDPE TRENCH DRAIN SYSTEM



Approval Date

Customer Approval

Job Location

Job Name

Wade Division / Tyler Pipe Assumes No Responsibility For Superseded or Voided Data
Dimensional Data (Inches/mm) are Subject to Manufacturers Tolerance and Change Without Notice.

WN900__-HLP

HIGH DENSITY 6" WIDE TRENCH DRAIN WITH 4" WIDE THROAT, RADIUS BOTTOM, INTERLOCKING ENDS, INTEGRAL OUTLET, REBAR SADLES, LOCK DEVICES, BLANK GRATE INSERTS AND PAINTED DUCTILE IRON PAVER SLOT GRATES.

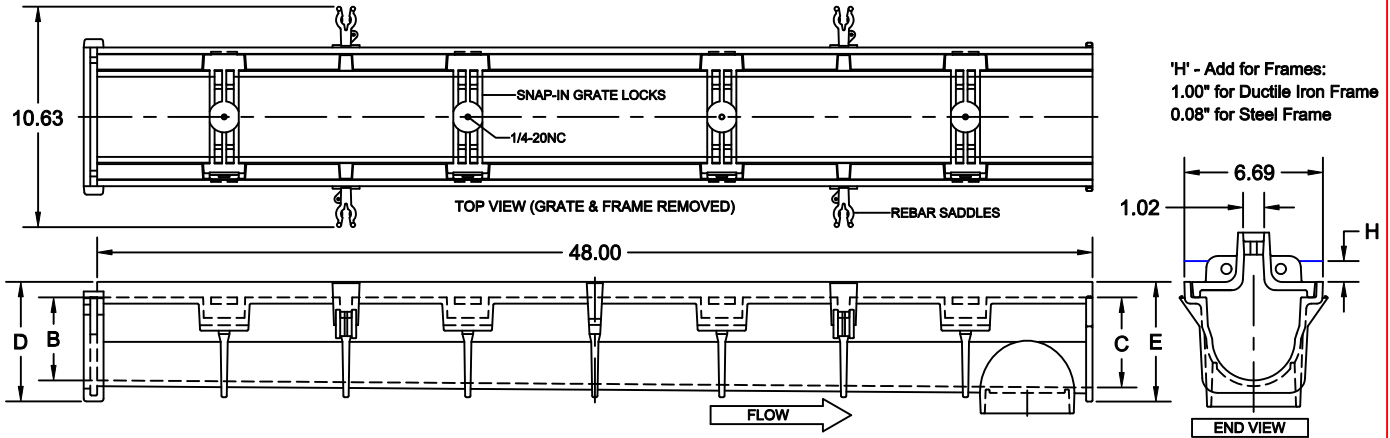

'H' - Add for Frames:
1.00" for Ductile Iron Frame
0.08" for Steel Frame

CATALOG NUMBER	FLOW RATE		DIMENSIONS (IN)				WT LBS
	(GPM)	(LPM)	B	C	D	E	
090N	75	284	3.998	3.998	5.354	5.760	7.45
091	75	284	3.998	4.334	5.690	5.770	7.52
091N	89	337	4.334	4.334	5.692	6.103	7.81
092	89	337	4.334	4.670	6.026	6.106	7.92
093	103	390	4.670	5.006	6.362	6.442	8.27
094	117	443	5.006	5.342	6.698	6.778	8.64
094N	131	496	5.342	5.342	6.700	7.111	8.93
095	131	496	5.342	5.678	7.034	7.114	8.99
096	145	549	5.678	6.014	7.370	7.450	9.37
097	159	602	6.014	6.350	7.706	7.786	9.74
097N	173	655	6.350	6.350	7.708	8.119	10.04
098	173	655	6.350	6.686	8.042	8.122	10.11
099	187	708	6.686	7.022	8.378	8.458	10.48
100	201	761	7.022	7.358	8.714	8.794	10.85
100N	215	814	7.358	7.358	8.716	9.127	11.15
101	215	814	7.358	7.694	9.050	9.130	11.23
102	229	867	7.694	8.030	9.386	9.466	11.60
103	243	920	8.030	8.366	9.722	9.802	11.97
103N	257	973	8.366	8.366	9.724	10.135	12.27
104	257	973	8.366	8.702	10.058	10.138	12.34
105	271	1026	8.702	9.038	10.394	10.474	12.71
106	285	1079	9.038	9.374	10.730	10.810	13.08
106N	299	1132	9.374	9.374	10.732	11.143	13.38
107	299	1132	9.374	9.710	11.066	11.146	13.45
108	313	1185	9.710	10.046	11.402	11.482	13.83
109	327	1238	10.046	10.382	11.738	11.818	14.20
109N	341	1291	10.382	10.382	11.740	12.151	14.50
110	341	1291	10.382	10.718	12.074	12.154	14.57
111	355	1344	10.718	11.054	12.410	12.490	14.94
112	368	1393	11.054	11.390	12.746	12.826	15.31
112N	382	1446	11.390	11.390	12.785	13.158	15.61
113	382	1446	11.390	11.726	13.082	13.162	15.69
114	396	1499	11.726	12.062	13.418	13.498	16.06

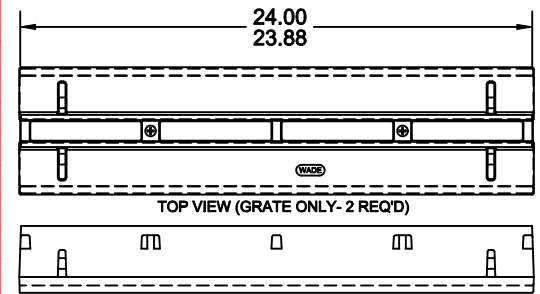

GRATE FREE AREA = 18.79 SQ.IN. (EACH)
TWO GRATES PER SECTION = 37.58 SQ.IN.

DIN CLASS	ASME CLASS	AASHTO H-20	FAA RATED	ADA
C	HD	YES	NO	NO

OPTIONS				
SUFFIX	DESCRIPTION			
HLG	GALVANIZED GRATES			
UEP	UNIVERSAL END PLATE			
US	UNIVERSAL SIDE OUTLET END PLATE			
	2"	3"	4"	6"
PA	PVC OUTLET ADAPTER			
	2"	3"	4"	6"
NH	NO-HUB OUTLET ADAPTER			
	2"	3"	4"	6"
DLP	PAINTED DUCTILE IRON FRAME			
DLG	GALVANIZED DUCTILE IRON FRAME			
CLP4	PAINTED STEEL FRAME			
CLG4	GALVANIZED STEEL FRAME			

AutoCad.dwg