

MILD TEMP WALL HYDRANT



8600MT-175

ANTI-SIPHON WALL HYDRANT WITH INTEGRAL BACKFLOW PREVENTER, ALL BRONZE INTERIOR PARTS, 3/4" FEMALE IPS THREADED INLET, KEY OPERATOR, TEE HANDLE KEY AND SATIN FINISH NICKEL BRONZE BOX WITH HINGED LID.

Approval Date

Customer Approval

Wade Division / Tyler Pipe Assumes No Responsibility For Superseded or Voided Data

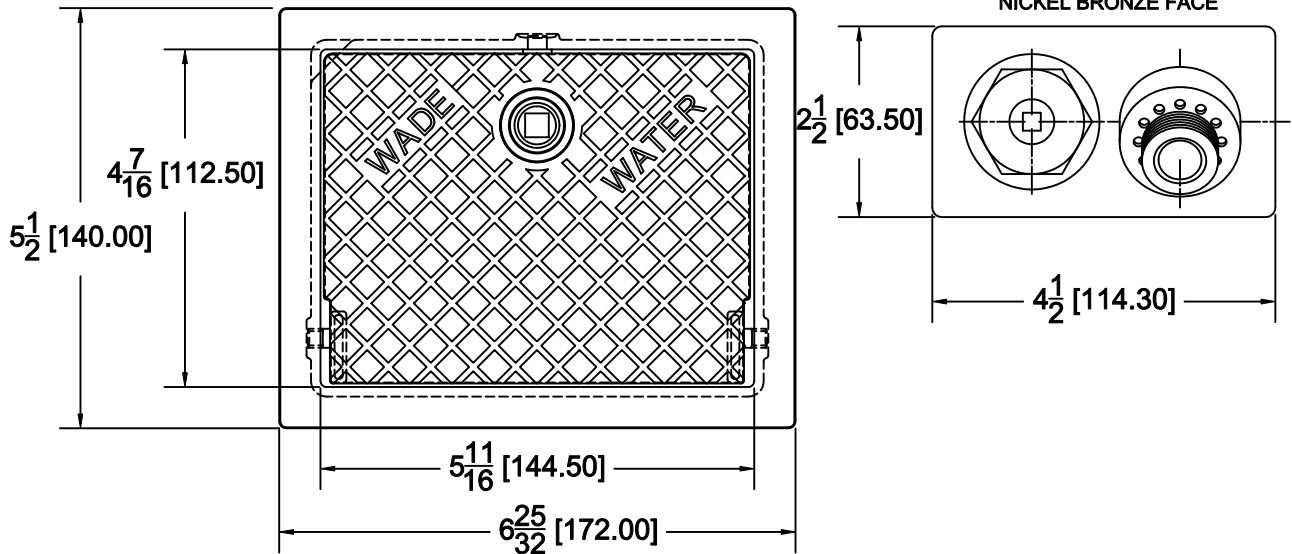
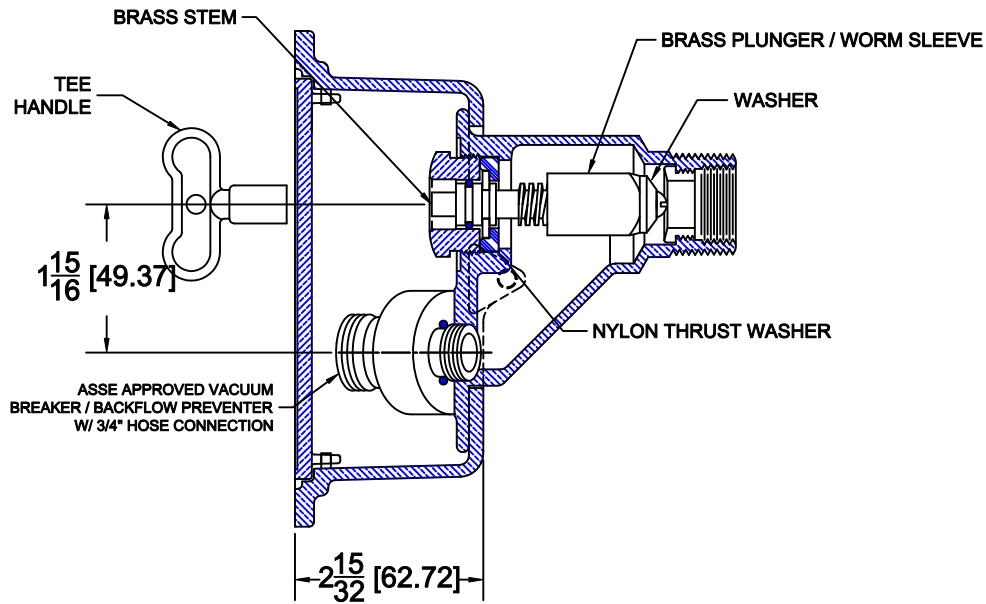

Job Location

Job Name

Dimensional Data (Inches/mm) are Subject to Manufacturers Tolerance and Change Without Notice.

MILD TEMP WALL HYDRANT



8600MT-175

ANTI-SIPHON WALL HYDRANT WITH INTEGRAL BACKFLOW PREVENTER, ALL BRONZE INTERIOR PARTS, 3/4" FEMALE IPS THREADED INLET, KEY OPERATOR, TEE HANDLE KEY AND SATIN FINISH NICKEL BRONZE BOX WITH HINGED LID.

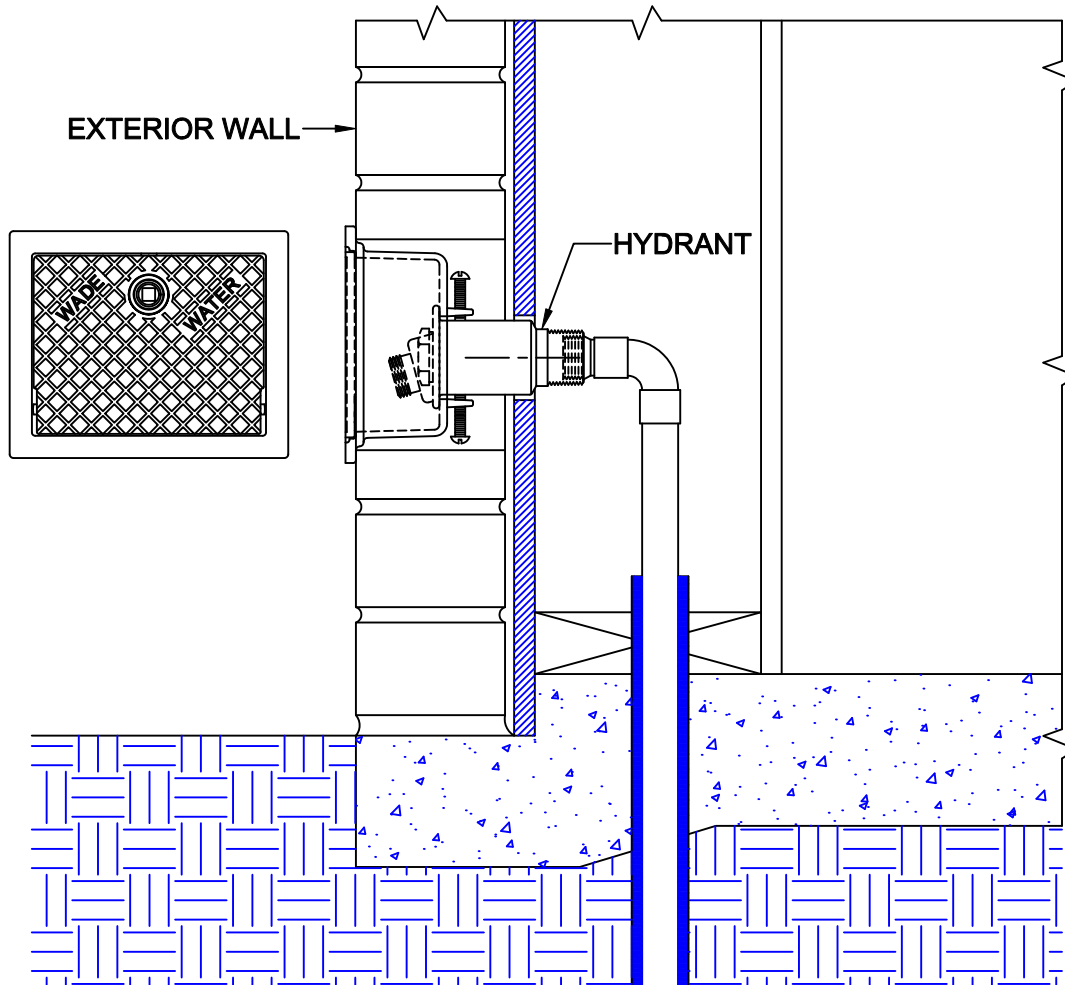

The Wade 8600MT-175 wall hydrant provides a flush fully enclosed installation in any type of wall construction. The hinged box cover can be locked to prevent vandalism. The key that unlocks the cover also operates the hydrant. The water supply piping is first run to an elevation above the finished floor level at the anticipated hydrant location. The piping should be insulated for protection against aggressive soils and concrete. The type of piping and connections are irrelevant - a standard 3/4" male NPT threaded adapter is all that is required. The piping should be accessible for connection after the concrete is poured.

After the concrete is poured and wall framing is complete, mount the hydrant through the exterior sheeting and into the interior wall. Before connection to the water supply, flush the supply piping to insure no debris exist which could damage or clog the hydrant. The box should extend out to the anticipated finish wall thickness. Use a high quality thread sealant and screw the adapter into the threaded hydrant tailpiece.

Care must be taken to protect the box face during installation. Use either cardboard, tape or other materials to protect the top during construction. After the finish wall is complete, open the box cover with the provided key and turn the hydrant on to insure the unit operates properly.

AutoCad.dwg

MILD TEMP WALL HYDRANT



Approval
Date

Customer
Approval

Job
Location

Job
Name

Dimensional Data (Inches/mm) are Subject to Manufacturers Tolerance and Change Without Notice. Wade Division / Tyler Pipe Assumes No Responsibility For Superseded or Voided Data

8600MT-175

ANTI-SIPHON WALL HYDRANT WITH INTEGRAL BACKFLOW PREVENTER, ALL BRONZE INTERIOR PARTS, 3/4" FEMALE IPS THREADED INLET, KEY OPERATOR, TEE HANDLE KEY AND SATIN FINISH NICKEL BRONZE BOX WITH HINGED LID.

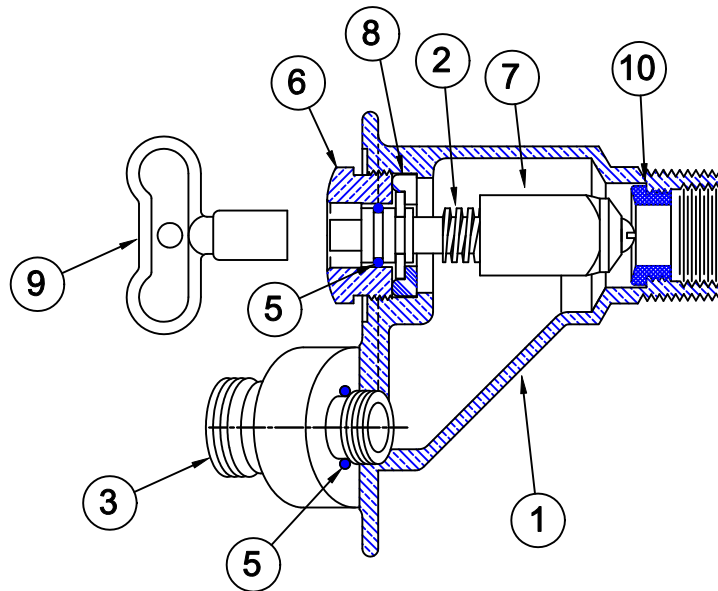

NO.	DESCRIPTION	UPC 670610
2,5,6 7,8,9	REPAIR KIT WK07	362111
NO.	DESCRIPTION	
1	HYDRANT HEAD	
2	OPERATING STEM	
3	VACUUM BREAKER	
4	O-RING (VACUUM BREAKER)	
5	O-RING (OPERATING STEM)	
6	STEM BUSHING NUT	
7	PLUNGER	
8	THRUST WASHER / SEAL	
9	OPERATING KEY	
10	NYLON SEAT	

MILD TEMP WALL HYDRANT



8600MT-175

ANTI-SIPHON WALL HYDRANT WITH INTEGRAL BACKFLOW PREVENTER, ALL BRONZE INTERIOR PARTS, 3/4" FEMALE IPS THREADED INLET, KEY OPERATOR, TEE HANDLE KEY AND SATIN FINISH NICKEL BRONZE BOX WITH HINGED LID.

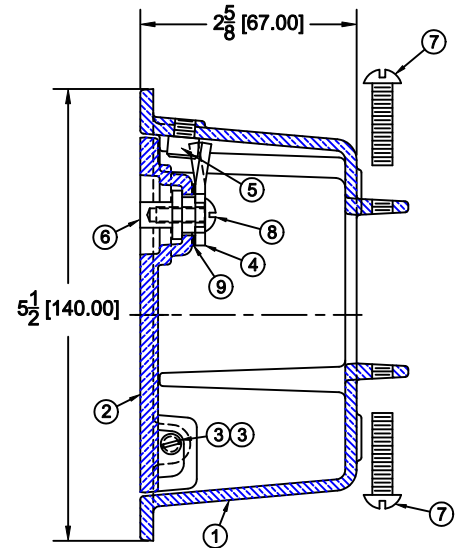
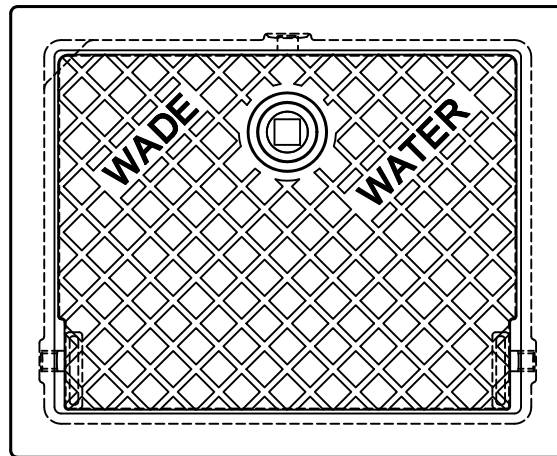
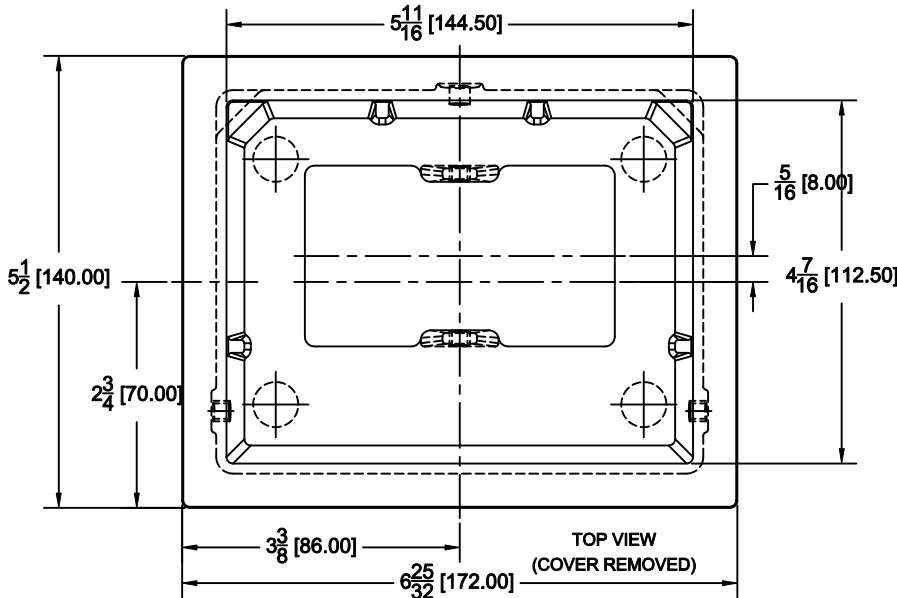

ITEM	QTY	DESCRIPTION	UPC (670610)	PART NO.
1	1	BOX (NICKEL BRONZE)	446903	8600-B2
2	1	LID (NICKEL BRONZE)	446910	8600-C2
3	2	HINGE PIN (BRASS)	232308	HD-9082-C
4	1	LATCH PAWL	429241	HD-2236-B
5	1	CATCH SCREW (BRASS)	232452	HD-9080-A
6	1	LATCH STEM (BRASS)	232278	HD-9081-B
7	2	BRASS SCREW 1/4-20NC x 1" LONG	226321	BD-32R
8	2	BRASS SCREW 10-24NC x 1/2" LONG	232292	HD-9511-B
9	2	PLASTIC WASHER	232285	HD-2236-A

Approval
Date

Customer
Approval

Job
Location

Job
Name

Waide Division / Tyler Pipe Assumes No Responsibility For Superseded or Voided Data

Dimensional Data (Inches/mm) are Subject to Manufacturers Tolerance and Change Without Notice.

MILD TEMP WALL HYDRANT



8600MT-175

ANTI-SIPHON WALL HYDRANT WITH INTEGRAL BACKFLOW PREVENTER, ALL BRONZE INTERIOR PARTS, 3/4" FEMALE IPS THREADED INLET, KEY OPERATOR, TEE HANDLE KEY AND SATIN FINISH NICKEL BRONZE BOX WITH HINGED LID.

Troubleshooting Guide

PROBLEM	CAUSE	SOLUTION
Hydrant will not operate when turned on	Water supply is off	Turn water supply on
Cannot turn the hydrant on with the key	Hydrant has not been operated for a long period - O-ring has adhered to stem and head	See service guide steps 1-2, 4-5 and 8-10
	Ceramic disc inside cartridge assembly is broken	See service guide steps 1-4.
Water sprays from holes around vacuum breaker nozzle when hydrant is on	Balance seal is damaged	See service guide steps 1-3 and 8-10
Water sprays from around the key operator when the hydrant is on	Operating coupling o-ring or the air relief orifice o-ring is damaged	See service guide steps 1-4
Hydrant weeps around the operating key area	This is normal (hydrant will self drain for a short period after it is off)	Take no action
Hydrant will not weep (self drain) after it is shut off and a hose is attached	The air relief orifice is blocked	Use a paper clip to evacuate debris from the orifice
Hydrant will not shut off completely	Cartridge assembly is loose or damaged	See service guide steps 1-4 (Verify that cartridge assembly is tight/seated)
	Debris in the ceramic disc or disc is damaged	See service guide steps 1-2, 4 and 6-10
Hydrant has low flow	Water supply to the hydrant is restricted	Check water supply to ensure that all upstream valves are fully open

Service Guide

Step 1: Shut Off Water Supply to Hydrant.

Locate the supply shut-off valve and actuate until water supply is off.

Step 2: Removing Internal Components

Use a wrench of appropriate size to remove the stem bushing nut by turning counterclockwise.

With a key operator, turn the drive screw 3 to 4 turns clockwise to let the drive screw assembly protrude slightly from the hydrant face. Using (2) screwdrivers or vise-grip pliers, pull to release the internal operating assembly.

Step 3: Replacing Operating Stem and Internal Seals

Unscrew the plunger assembly from the operating stem. Screw a new plunger onto assembly onto the stem.

Reassemble the operating screw, plunger, thrust washer.

Insert assembly into the hydrant with the square drive sleeve aligned with its square bore.

Unscrew the drive screw from the sleeve and install the nylon thrust washer / seal and stem bushing nut.

Re-install the stem bushing nut.

Operate the hydrant fully open and closed to check for normal operation.

Step 4: Turn On the Water Supply

Locate the water supply valve and actuate open. Open and close the hydrant to ensure it works correctly.

Approval Date

Customer Approval

Job Location

Job Name

Dimensional Data (inches/mm) are Subject to Manufacturers Tolerance and Change Without Notice. Wade Division / Tyler Pipe Assumes No Responsibility For Superseded or Voided Data