

CLOSET CARRIERS



340-A-HD SERIES (500 LB)

NO-HUB ADJUSTABLE VERTICAL WATER CLOSET CARRIER WITH 4" NO-HUB CONNECTIONS, 2" NO-HUB VENT CONNECTION, UNIVERSAL FLOOR MOUNT FOOT SUPPORTS, REAR ANCHOR SUPPORT (SINGLE CARRIERS), ABS PLASTIC CLOSET COUPLING W/ O-RING SEAL & INTERNAL WRENCH GROOVES, 5/8" HEAVY DUTY SUPPORT HARDWARE, NEOPRENE BOWL GASKET, INTEGRAL TEST CAP, ADJUSTABLE GASKETED FACE PLATE W/ REMOVABLE LUGS AND PLASTIC STUD PROTECTORS.

THIS SYSTEM COMPLIES & EXCEEDS ALL REQUIREMENTS OF ANSI A112.6.1M (UP TO 500 LBS)

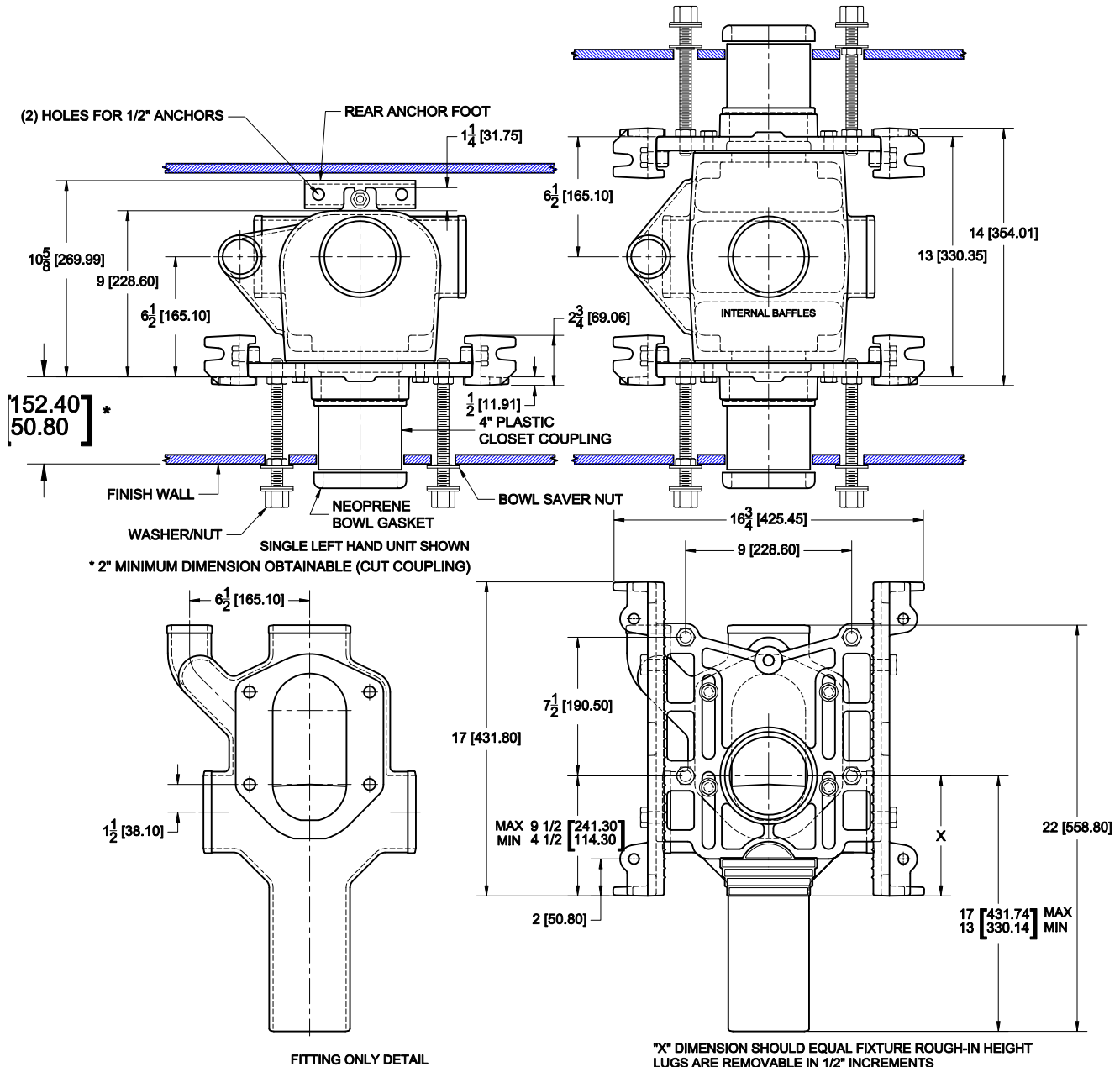

OPTIONS

Suffix	Description
AM1	FLUSH VALVE SUPPORT
AM27	TILE FINISHING FRAME

CAT.NO.	WT.LB.
340-A-NL-HD	95.0
340-A-NR-HD	95.0
340-A-ND-HD	115.0

AutoCad.dwg